

2005-xx (2005. x. x)

()

2005. 1

I.

II.

1

2

3 가

4

5.

6

III.

IV.

1

2.

, , ,

3.

4.

, , , n-

iso-

5.

V.

1

/

2

)

3.

)

4.

5.

6.

:

(QA/QC)() ----- 108

2005-xx (2005. x. x)

()

2005. 1

I.

II.

1

2

3 가

4

5.

6

III.

IV.

1

2.

, , ,

3.

4.

, , , n-

iso-

5.

V.

1

/

2

)

3.

)

4.

5.

6.

:

I.

1.

5

2.

(“ ”) (QA/QC) ,

3.

12가

[3] 2

4.

5.

“)

(

6.

6.1

5 m

6.2

5 m

6.3 “6.1. 6.2 “

7.

8.

9.

10.

11.

KSA 3251 -1(

12.

13.

II.

1.

1.

2.

1961

3

(SI) 1 , KSA 0105

4.

4.1

%

4.1

100 mL

100 mL

(g)

W/V%

4.2

100 mL

100 mL

(mL)

V/V%

4.

(Parts Per Million)

ppm

mol/mol

(V/V),

mol/mol

(W/W),

(W/V)

4.4 10

(Parts Per Billion)

ppb

ppm

	()	m cm mm $\mu\text{m}(\mu)$ $\text{nm}(m\mu)$			KL L mL μL m^3 cm^3 mm^3 atm mmHg mmH ₂ O
	()	kg g mg μg ng m^2 cm^2 mm^2			

5.1 (Celcius)
 5.2 K, 0 K -273, (冷所)

5.3 (冷水) 0~15, 15, (温水) 60~70, (熱水) 100

6

7 (脱鹽水)

8

8.1 (1+2), (1+5), (1+5+10) 1
 2, 1, 5, 1, 5, 10, (1+2)
 (1:2), (1:5), (1:5:10)
 (1:2) 1, 2

8.2 (1:2), (1:5)
 1 g, 1 mL, 2 mL, 5 mL

9.

9.1 1,

2

		(%)	()
	HCl	35.0 ~ 37.0	1.18
	HNO ₃	60.0 ~ 62.0	1.38
	H ₂ SO ₄	95%	1.84
	CH ₃ COOH	99.0%	1.05
	H ₃ PO ₄	85.0%	1.69
	NH ₄ OH	28.0 ~ 30.0 %(NH ₃)	0.90

9.2

10 (滴數)

20 20 가 1 mL

11. (器具)

11.1 KSL 2302(가) 가

11.2 가 , , , ,

11.3 “ ” KSM 7602 5

12 (容器)

12.1

12.2 (密閉容器) (異物) 가

12.3 (機密容器) 가

12.4 (密封容器)

12.5 (遮光容器)

13 (天秤)

가

14

14.1 “ ”
1 가 g 0.3 mg .

14.2 “ ” 30 .

14.3 “ ” 15 mmHg .

14.4 “ ” “ ” “ ” “ ” (以) 가
“ ” (起算點) (基準點) “ ”
“ ” . “a~b”
a b .

14.5 “ (空試驗) ” .

14.6 , (Lot) ,

14.7 “ (洗滌) ”
, (濾過膜)
(洗液) .

14.8 (液性) pH

15.

15.1

15.2 KSA
3251 - 1(- 1 :) .

15.3 가

2. (Absorptiometric Analysis)

1.

가

(發色)
200 ~ 900 nm

2.

(光源)

(Monochrometer)

(Filter)

(光束)

(光電測光)

I_0

1

C,

가

I_t I_0

-

(Lambert-Beer)

가



그림 1. 흡광광도 분석방법 원리도

$$= I_0 \cdot 10^{-\epsilon C l}$$

(1)

- I_0 :
- I_t :
- C :
- :

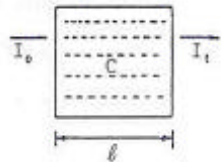
(吸光係數)

$$C = 1 \text{ mol}, l = 0 \text{ mm}$$

K

$$\frac{I_t}{I_0} = T \quad (\text{透過度}), \quad \log \frac{100}{T} = A$$

(吸光度)

I_t
(對照液層)

$$A = cl$$

()

가

가 가

3.

3.1

(波長選擇部), (試料部) (光源部),
(光學系) (測光部) 가

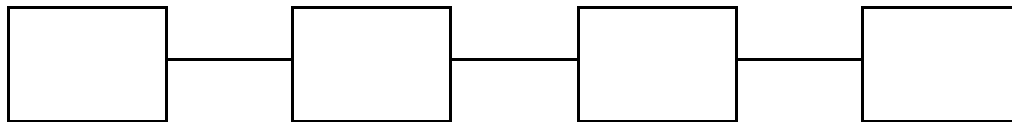

2.

3.2

(點燈) (重水素放電管)
가 (可視部) (近赤外部) (光學系)

(紫外部)

3.3

(Monochrometer) (Filter)
가
(Slit)

3.4

(Cell,)
(Cell Holder)
(光路) (試料室)

3.5

(光電管), (光電子増倍管),
(指示計), (增幅器) (對數變換器)가
(近赤外) 가
(光電測光) 가

6

(復光束型) (單光束型)
(示差測光) 가 (微分測光), 2 (二波長測光)

3.7

가

3.8 (吸收 Cell)

3 4

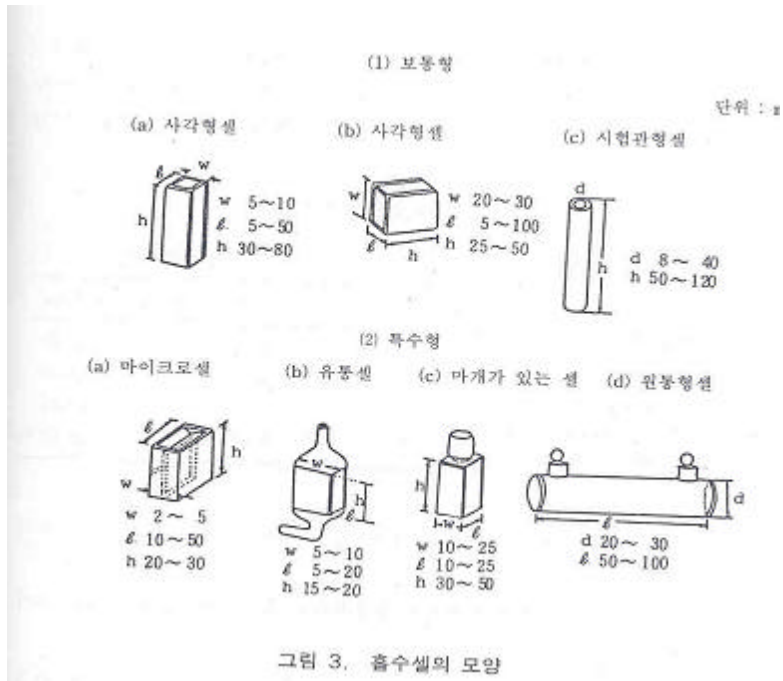

3 (a) 1 mL (液層) 10 mm , (b) 가 , (c) 가 50 mm , (d) 가 (近赤外) , 가 (可視)

3.9

3.9.1

(Line Spectrum)

4
 가
 가 (Zero) m . m (眞波長) t
 1 .



그림 4. 파장눈금고정을 위한 선스펙트럼 측정보기

1.	
	(nm)
	486.13
	656.28
	486.00
	656.10
	253.65
	365.01
	435.88
	546.07

3.9.2

(Holmium)

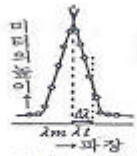
5 1 nm
 가 (走査速度)가
 가 (走査)

가

3.9.2

110 3 (1) N/20

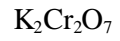

0.0303 g/L가

10.0 mm

25 1 nm

2

2



그림 6. 미광조사용 커트필터의 투과율(%)

5. 1 nm

2. (%) (25)

(nm)		(%)	(nm)		(%)
------	--	-----	------	--	-----

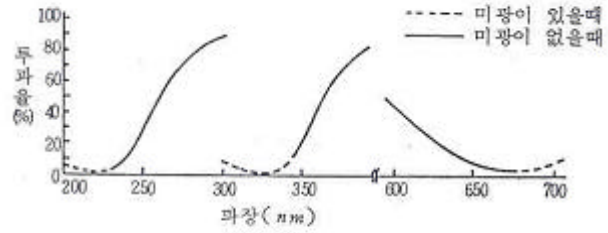
220	0.446	35.8	340	0.316	48.3
230	0.171	67.4	350	0.559	27.6
240	0.295	50.7	360	0.830	14.8
250	0.496	31.9	370	0.987	10.3
260	0.633	23.3	380	0.932	11.7
270	0.745	18.0	390	0.695	20.2
280	0.712	19.4	400	0.396	40.2
290	0.428	37.3	420	0.124	75.1
300	0.149	70.9	440	0.054	88.2
310	0.048	89.5	460	0.018	96.0
320	0.063	86.4	480	0.004	99.1
330	0.049	71.0	500	0.000	100

3.9.3 (迷光, Stray Light)

(限定使用波長域)

3

(迷光, Stray Light)

6

(Cut Filter)

3.

(nm)	
200 ~ 220	,
300 ~ 330	
700 ~ 800	

4.

4.1

4.1.1
4.1.2
4.1.3
4.1.4
4.1.5

가 가 가

4.2

4.2.1 370 nm

370 nm

4.2.1 (L) 10 mm

4.2.1 , (8)
(方向性)

4.2.1

가 (2 W/V %) 가 (:)
가 가 40 ~ 50 10 가 가 30
(1 +5) 가 가

(Dryer)

가

(紫外域)

4.3

4.3.1

4.3.2

(Zero)

4.3.3

4.4

4.4.1

가

4.4.2

(光路)

(光速)

가

4.4.3

100

4.4.3

(光路)

(指示値)

4.4.4

100

가

가

4.4.6

“2 ”, “3 ”, “4 ”

4.5

(吸收曲線 測定)

10 nm

(가)

()

(Peak)

1 ~ 5 nm

가

(縱軸)

(自記分光光電光度計)

4.6

4.6.1

4.6.2

4.6.3

4.6.4

4.6.5

4.6.6

4.6.7

4.6.8 가

4.6.9

4.6.10

5.

()

5.1

가

가

(片對數)

5.1.1

(純物質)

5.1.2

5.2

5.2.1

5.2.1.1

5.2.1.2

5.2.1.3

5.2.1.4

pH

가

5.2.1.5

가

5.2.1.6

,

가

5.2.1.7

5.2.1.8

가

가

5.2.1.9

5.2.1.10

(光)

5.2.1.11

5.2.2

5.2.2.1

가

(次善)

5.2.2.2

5.2.2.3

0.2 ~ 0.8

5.2.2.1

0.1

5.3

5.3.1

(被檢液)

5.3.2

가

5.3.3

가

5.3.4

가

5.3.5

5.3.6

4.4

5.3.7

5.1

:

가

.

3. 가

1.

가

?

2.

2.1

(GSC) , (solid support)
(GLC)

2.1

(carrier gas)

2.3

가 ,

2.4

(PC
(peak)

)
(chromatogram)

가

2.5

(retention time)
(retention volume)

가

3.

가

(GC)

(),

3.1

3.1.1

가

3.1.2

3.2

3.2.1

가 가

3.2.2

가

3.3

(column oven)

가 (),

가

± 0.5

가

10 %

가 ± 0.5

3.4

GC

가

3.4.1

(flame ionization detector, FID)

(nozzle),

(ion collector)

3.4.2

(electron capture detector, ECD),

(flame photometric detector, FPD),
detector :NPD)

(nitrogen phosphorus

3.5 (Mass Selective Detector)

3.5.1

가 가
가 가
가 ,

3.5.2 (electron impact ionization, EI)

(M) (M⁺)
(ionization energy, IE) , 8~12 eV
(800~1200 kJmol⁻¹)가



가 (fragment ion)

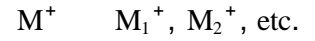

10⁻⁵ torr ()

가 70 eV

(m/z)
(Library)

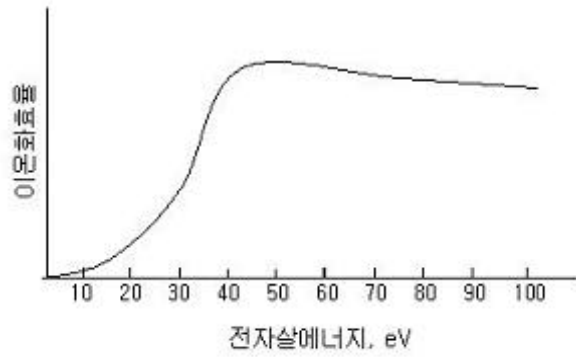

3.5.3 (mass analyzer)

(m/z)
(analyzer)

3.5.3.1 (Quadrupole analyzer)

$$x^2 - y^2 = r_0^2$$

z

(Potential pulse)

가

(U)

(V cos t)

3.5.3.2 (Ion trap analyzer)

(Ring)

(End cap)

가 (U + V cos t)가
m/z 가

가 가

가

가

3.5.3.3 (electron multiplier, EM) Cu-Be

(dynode)

12

20

가

99.999 %

가

5.

5.1

가

가

가 chromatography)

가 GSC(Gas-solid chromatography)

GLC(Gas-liquid chromatography)

가

가

가 가

5.2

5.2.1

30 ~ 60 (mesh), 60 ~ 80 , 80 ~ 100 가 가

(molecular sieve),

5.2.2

가

가

5.2.2.1 (Support)

가

(silane finishing)

5.2.2.2 (Stationary liquid)

(Stationary liquid)

가

가

가

5.2.3

(Divinyl benzene) 가 (Bridge intermediate)

6.

6.1

6.1.1 가 / (GC/MS)

가 가 85%

6.2.2

5.2.2.1 : ,
± 10 %

5.2.2.2 : , 가

5.2.2.3 : 10

6.2

6.2.1

6.2.1.1 가 : 가 , 가
가 가 가

6.2.1.2 :

6.2.1.3 가

가

6.2.2

6.3

6.3.1

6.3.1.1 가

6.3.1.2 MS (transfer-line)

6.3.1.3 (, ,)

6.3.1.1

6.3.2

6.3.3

6.3.3.1 가 : 가 (0.5 ~ 5 mL)

6.3.3.2 : (micro

syringe, 1 ~ 100 μL)

6.3.3.3 : “6.3.3.2 ”

7. 가

가

7.1

(theoretical plate number)

(height

equivalent to a theoretical plate, HETP)

(1)

()

-
- (m)

7.2

가

(2)

, - 1
- 2
- 1
- 2
- d : (t_{R2} - t_{R1})

8.

가

가

(library)

(relative retention),

가

(retention time),
(retention ratio),

(retention volume),
(retention index)

5 ~ 30

3

± 3 %

(dead volume)

9.

, ,

9.1

9.1.1

가 (GC)

9.1.2

가

(3)

9.1.3

(X) (S) 가

(M_X) (M_S) (M_X/M_S)
(A_X/A_S) (A_X) (A_S)

(M) (n) 가

가 가 , 가

(A) (M) (M) (M/M)가 (A) (A/A)

(X)

(4)

가

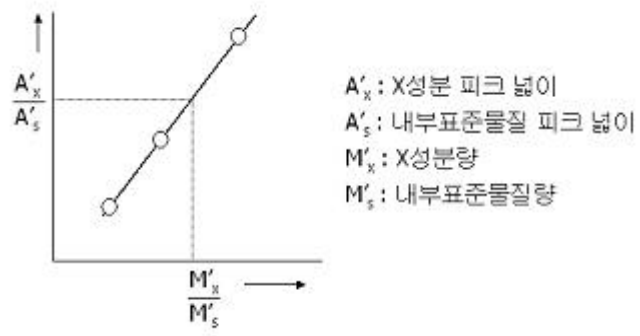

9.1.4 가 :
 a_1 b_1

A B A B
 W_A W_B a_2 b_2 K

(5)

W_A W_B A B K
 A $X(\%)$

(6)

9.2

“9.1 ” (mole)

9.3

(noise) 3 (S/N >3)

9.4

가 ± 20 %

10.

가

10.1 :

10.2 : , ,

10.3

10.3.1 : , , 가

10.3.2 가

10.3.2.1

)

10.3.2.2 :

10.3.2.3 :

10.3.2.4

,

10.3.3

10.3.3.1 :

10.3.3.2 :

10.3.3.3 :

10.3.4

10.3.5

10.3.5.1 :

10.3.5.2 :

10.3.5.3 :

10.3.6

10.3.6.1 :

10.3.6.2 :

10.3.6.4 :

SI mole .

4. (Ion Chromatography)

1.

(F⁻, Cl⁻, NO₂⁻, NO₃⁻, PO₄⁻, Br⁻ SO₄⁼) .

2.

1 , ,

, ,

()



그림 1. 이온크로마토그래프의 기본구성

2.1

10 μm

가 (脈動)

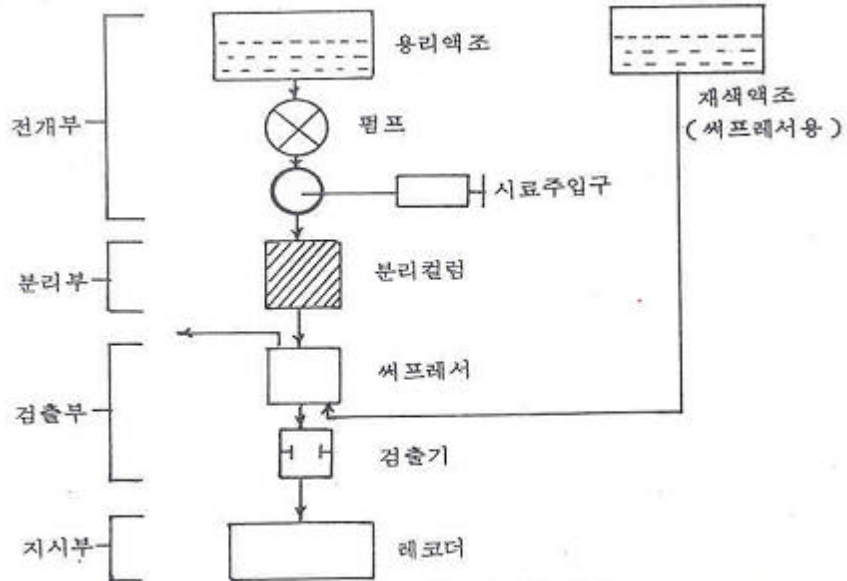
150 ~ 350 kg/cm^2

2.2

50 ~ 100 μl

2.3

2.3.1

(10 ~ 15 μm)

3 ~ 5 mm, 5 ~ 30 mm

2.3.2

(10 ~ 12.5 μm) (10 ~ 15 μm), (6 μm)
4 ~ 6 mm 5 ~ 10 cm .

2.4 ()

가
가

2.5

3.
3.1

μm (GF/C) 0.45

3.2

3.2.1 (1 mg/M ℓ)

105

1 L .

1

--	--	--

C1 ⁻	NaCl	1.6485
Br ⁻	NaBr	1.2876
NO ₃ ⁻	NaNO ₃	1.3707
NO ₂ ⁻	NaNO ₂	*1.4998
PO ₄ ⁻	KH ₂ PO ₄	1.4330
SO ₄ ⁼	K ₂ SO ₄	1.8141
F ⁻	NaF	2.2100

*

3.2.2

3.2.3 (1)

3.2.3.1 (0.003M NaHCO₃ - 0.0024M Na₂CO₃)

1.008 g 1.0176 g 4 L

3.2.3.2 (0.0013M - 0.0013M Na₂B₄O₇)

1.02 g 1.0466 g 4 L

3.2.4 (0.025N H₂SO₄)

2.8 mL 4 L

3.3

1 ~ 3 mL/

가

3

3.4 (2)

(mg/L)

1)

2)

5. (HPLC)

1.

가

2.

2.1

가

HPLC

가

2.2 HPLC

3.

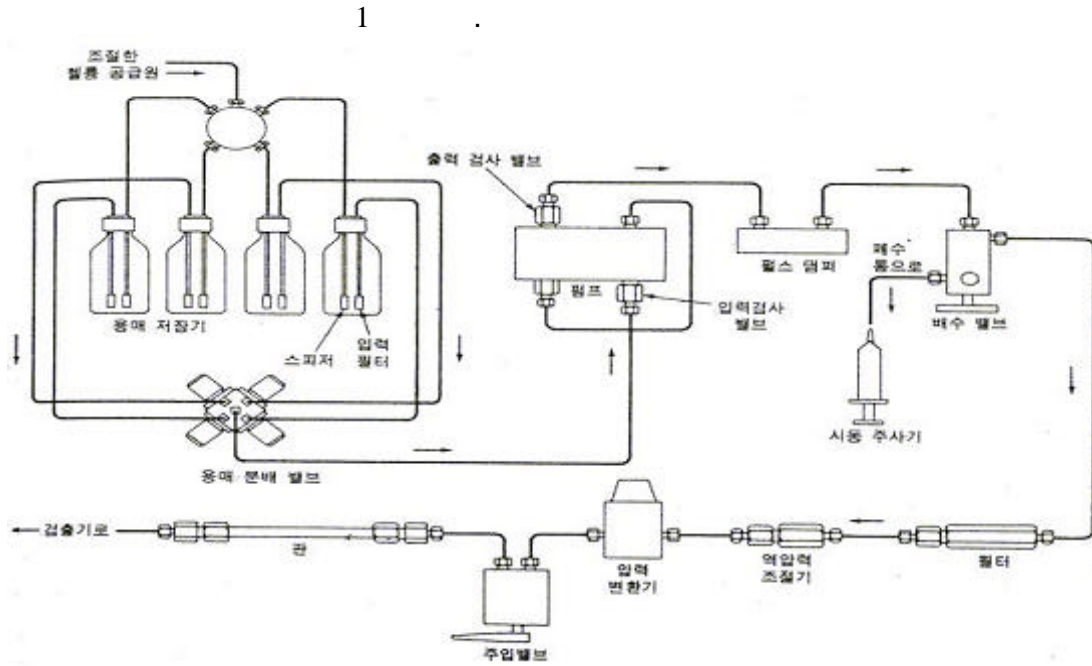

3.1 HPLC

HPLC

, PTFE, PEEK,

가

가

3.2 HPLC

HPLC

HPLC

18MΩ

가 15

(v/v)

HPLC

()

3.2.1

3.2.2

1 ~ 10

가

3.2.3

3.2.4

3.2.5

가

3.3

(Degassor)

HPLC

1

He

가

가

3.4

, 가
가

가

HPLC

3.4.1

3.4.1

500 psi

가

3.4.3

0.1 ~ 10 mL/

가

3.4.4

가

3.4.5

0.5 %

3.4.6

가 가

3.5

HPLC
 HPLC 가 (Sample loop)
 2.0 μL ~ 5.0 mL
 20 μL 가 가

3.6

HPLC 5,000 psi
 가 10 ~ 30
 cm 4.6 mm, 5 μm , 40,000 ~ 60,000 plate/m
 (analytical column) (guard column)
 column) 가 5 ~ 10 cm
 가
 HPLC 가 가
 가

3.7

HPLC 가 가 가

3.7.1 -가 (Ultraviolet-visible detector)
 HPLC 가 -가
 가

	가
	-
	-

	- 가 $10^{-6} \sim 10^{-10}$ g . - - 가 .
	가 .

4.

4.1

“3. 가 ”

4.2

4.2.1

4.2.1 가

4.2.2

4.2.3

4.2.4

4.2.2

4.2.3

1 ~ 2 mL/min
가

4.2.4

4.2.5

4.2.5.1

4.2.5.2

4.2.5.3

(μL mL)

4.2.5.4

4.2.5.5

4.2.5.6

4.2.5.7

4.2.5.8

5.

(Differential Optical Absorption Spectroscopy)

1.

(?) 50 ~ 1,000m (Path)
 가 , 180 ~ 2,850 nm
 (Xenon)

2.

2.1.

(Differential Optical Absorption Spectroscopy : DOAS)
 Beer-Lambert

$$I_t = I_0 \cdot 10^{-C} \quad (1)$$

- I_0 :
- I_t :
- C :
- :
- :

가 가 가 (I/I₀) , 1 (nm)
 가 1 (DOAS)
 () () (DOAS)

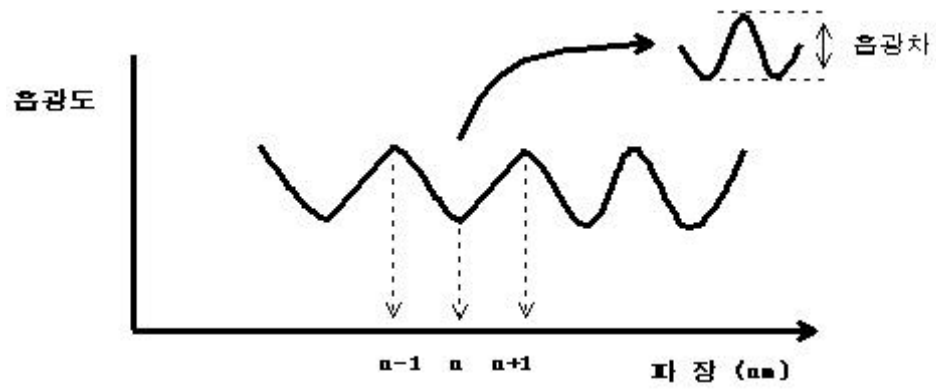

1.

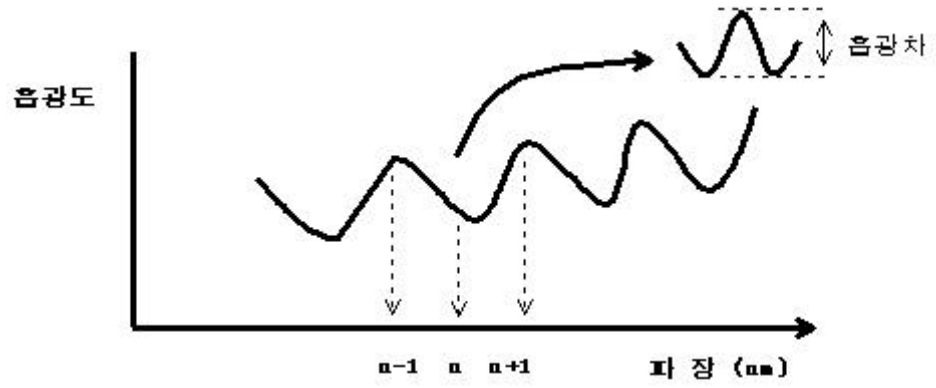

2.

가 1, 1 Y
 가 1, 2가
 가 2
 (1) .
 가 Differential Optical Absorption
 가 .. 가
 가 가
 , ,

(Fitting)

(,)

가

2.2.

Czerny -Turner

가

Holographic

가 가

(Photo Multiplier Tube)

PDA (Photo Diode Array)

(Detection Window)

A/D

A/D(Analog/Digital)

3.

3.1.

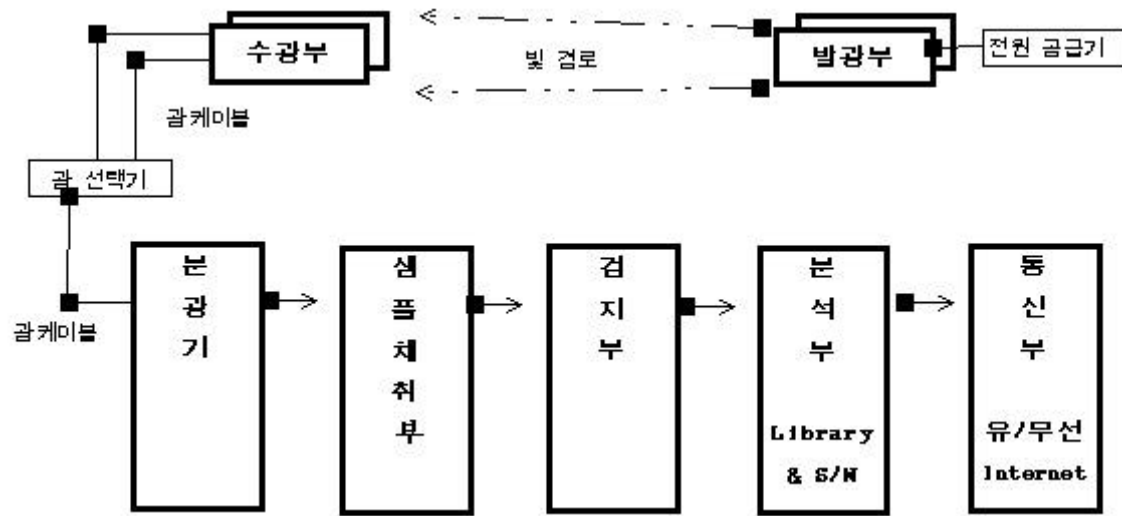

3.

3.2.

/ (?) ,

3.2.1

/ ?

180 ~ 2850nm

3.2.2

3.3.

가
가

3.3.1.

Czerny -Turner

Holographic

, 가 가 가

3.3.2

(Path)

3.3.3

PDA

3.3.4

(Library Data Base)

4.

?

가

4

?

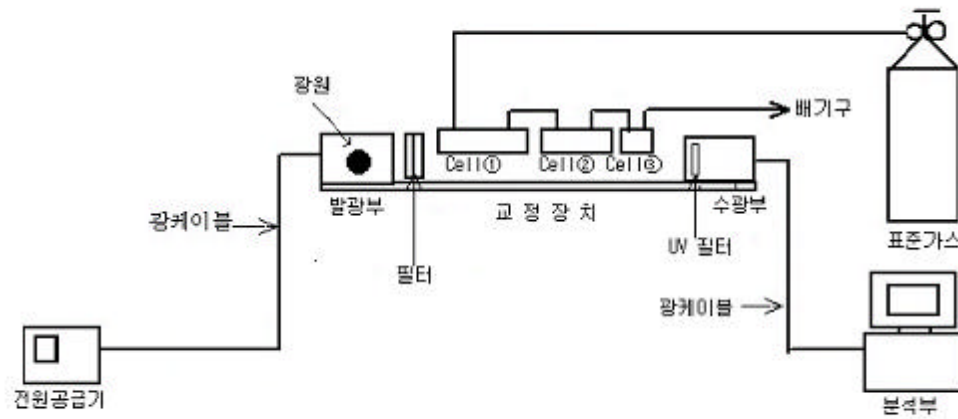

4.

4.1.

4.1.1.

(SO₂),

가

(NO_x)

3

4.1.2.

(O₃)

가 () 가 () 가
3)

SODA LIME
0.01Vol.ppm

KI

4.2.

가 24
5%

4.3.

2 가 가 (24)

4.4.

4
가 가

4.5.

가 A 가 가
10 B +10%
10 C -10%
B-A, C-A (RANGE)

4.6.

) AC 1000V 1 가 ()

4.7.

)
DC500V
KSC1031 KSC1302 (

4.8. 가 0 ~ 1V 1 ~ 5V(500)
4 ~ 20mA

4.9. 가 가 가
가 , 가 90%
()

4.10
(20 ~ 30) 5

5.

5.1. SO₂ O₃

0.2 vol.ppm 가 가 가 가
가

$$Rt = (A-B)/C \times 100 \quad (2)$$

- Rt : (%)
- A : 가 (vol.ppm)
- B : 가 (vol.ppm)
- C : (vol.ppm)

5.2. O₃

6.1.3 ,

6.1.4 ,

6.1.5 .

6.2

6.2.1 .

6.2.2 가

6.2.3 2

6.2.4 가 ?

6.2.5 ?

6.3.

가

가

6.4.

6.4.1 (Path)

6.4.2 ? 6 1 .

6.4.2 ? .

II.

1.

1..

1.1

	()		()	
	1000	500	500 ~ 1000	300 ~ 500
	20	15	15 ~ 20	10 ~ 15

1.2

2.

가

3.

3.1

3.1.1

가

1 , , ,

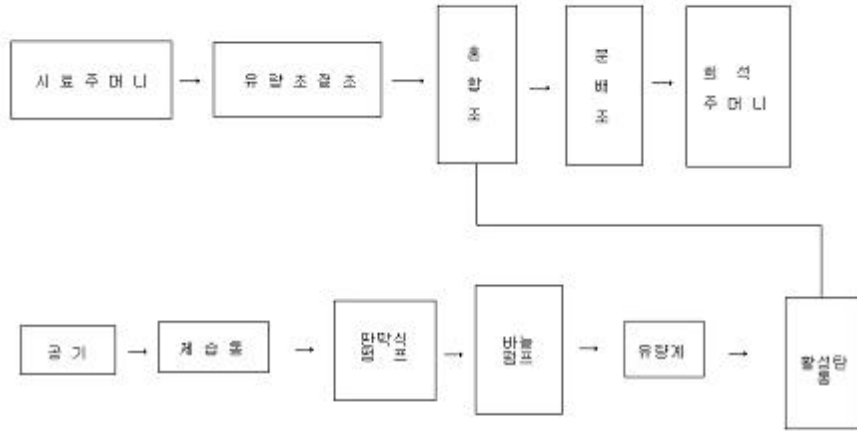

1.

3.1.1.1 (mass flow control)

3.1.1.2

3.1.1.3 (Diaphragm pump)

3.1.1.4

3.1.1.5

3.1.1.6

가

3.2

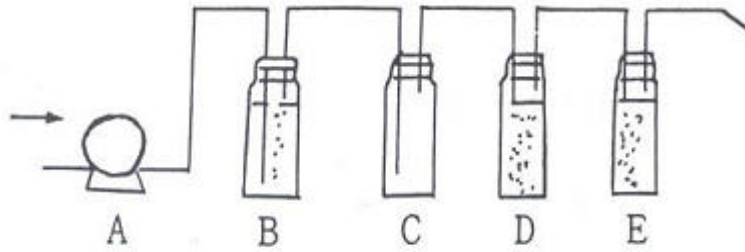

A : 흡인펌프 D : 실리카겔병
무수물(조각수) 무수물(조각수)

2.

3.3

(“ ”) (“ ”)
) , (Teflon) , (Tedlar), (Polyester)
 . (silicone rubber) (natural rubber) 3 ~ 20 L
 (seals and joints) 가 .

3.4

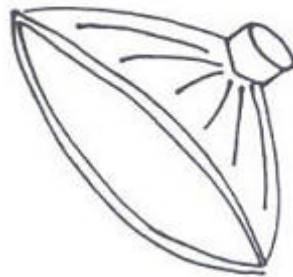

3.

3.4

3.4.1

5 L/ () (:

3.4.2

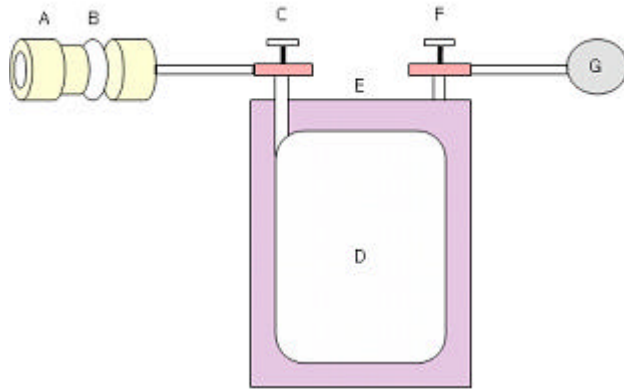

- A: 시료채취용더
- B: 필터
- C: 불소수지제 콕크
- D: 시료채취 주머니
- E: 간접진공 용입상자
- F: 용입 콕크
- G: 유량계용 갖은 용입 펌프

3.5 ()

1mL 가 (gas tight syringe) (glass)
가 .

4.

4.1 ()

1.

Acetic Acid	1.0 wt %	
Trimethylamine	0.1 wt %	

Methylcyclopentane	3.2 wt %	,
-Penylethylalcohol	1.0 wt %	

4.2 : 14 cm, 7 mm ,

5.

5.1

5.1.1

5.1.2

5.1.3 (, , ,)

5.2

1

5.3

1

10

5.4 ()

5.4.1

“5.1 ” 가 가

5.4.2

5.4.2.1

5.4.2.2 가 3

5.4.2.3 가 1

5.4.3

5

5.5

((:))

5.5.1

5.5.1.1

가

가

가

5.5.1.2

가

, 가 가

가 가

5.5.1.3

가 가

1m

5.5.2

5.5.2.1

5.5.2.2

3

5.5.2.3

1

5.5.3

가

가

5

(glass wool)

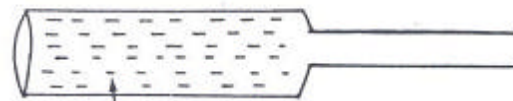

유리섬유

5.

5.6

(15 ~ 25)

(: ,)

5.7

48

6.

6.1

6.1.1 (14cm, 7mm)5 1 4 (5
“ ”) 1 1cm

가 .
6.1.2 5 1 가
4 4 가 3,4

2.

0	(None)	
1	(Threshold)	
2	(Moderate)	
3	(Strong)	
4	(Very Strong)	
5	(Over Strong)	

6.1.3 5 (Panel)

6.1.4 5

6.1.5 19

6.1.6

6.1.6 가

6.1.7

6.2

6.2.1

6.2.2

6.2.3

6.2.4

30

6.3

DB

6.3.1

6.3.2

?

7.

7.1

가

7.1.1

7.1.1.1 “3.3

”

3 ~ 20 L

7.1.1.2

가

7.1.1.3

5

가

가

(

“

가

”

)

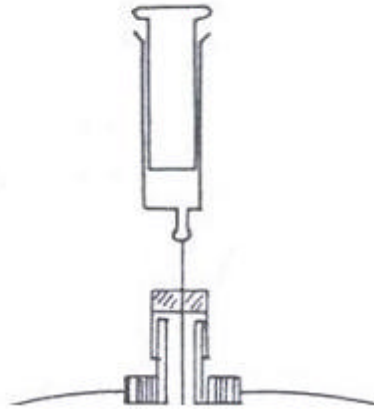

5.

7.1.1.4

가)

(“

7.1.1.5

2

7.1.1.6

3 (10 , 30 , 100)
1000 , 3000)

가

(300 ,

7.1.2

7.1.2.1

7.1.2.2

7.1.2.3

가

30

“ ”

7.1.2.4

3

7.1.2.5

2

7.1.2.6

10

가

()

7.1.2.7

1

(1 2

)

7.1.2.8

7.2

가

7.2.1

7.2.1.1.

가

가

(,

, ,)

7.2.1.2.

7.2.1.3

7.2.2

7.2.2.1

가

5

7.2.2.2

(

10 ,

300)

1

2 1 2

7.2.2.3

4

“

”

“

”

2~3

7.2.2.4

가

7.2.2.5

0.6

1.00,

0.00

7.2.2.6

가 2

가

0.60

가

가

2

가

1

가

가

가

7.2.7

5

8.

8.1

(“ ”) .

8.2

	1 가		2 가	3 가
	1 (×10)	1 (×10)	(×300)	(×1000)
a	x			
b				(가)
c		x		
d				x
e			x	

가 (1) : 1 (2 가 0.8) “ ” :
 , “ x ” :

(1)

a	a = 5.477	()	?(5.477 × 300 × 10) = 25
b	b = 1000	()	
c	c = 5.477		
d	d = 300		
e	e = 10		

(: 10 3)

8.3

가

8.5

(1)	(200 .	.	.	(:	~
(2)						
(3)						
(4)						
(5)						

(6)	m) (,)	
(7)		
(8) (, ,)		
(9)	가 . () 가 . () , (가) , . ()	
(10)		
(11) 가		

III.

1. ()

1.

1.1

가

1.2

ppm , 1 ppm . 1 ~ 2 ppm 0.01 ppm 2

2.

2.1 :

2.2

2.2.1 ()

1

2.2.1.1 , 20 mL 가 가

1 20 mL

2

2.2.1.2 10 L/

2.2.1.3 1 ~ 15 L/

2.2.2

2 (Filter) 가
5 % ?

3.

3.1

3.1.1

5 g

1 L

3.1.2

5 g

500 mL

()

()

2

25 mg

1

3.1.3

(

3 ~ 10 %)

60/CmL[

C

(NaOCl)

(%)]

10 g

12

35.8 g

1 L

()

() 10 mL

200 mL

가 10 mL

300 mL

가 100

mL

1 ~ 2 g

(1+1) 6 mL

50 mmol/L

(1W/V%) 1 mL

10 mL

50 mmol/L

"a"mL factor

(1)

3.2

3.2.1

130

[(NH₄)₂SO₄] 0.295 g

1 L

50

1 mL

2 uL(0 1)

3.2.2

0 ~ 40 mL

가 50 mL

10 mL

4.

4.1

1 10 L/ 5 ,

4.2

2 (polytetrafluoroethylene : PTFE)
(Quartz filter)
가 10 ~ 20 L/ .

5. (QA/QC)

5.1

5.1.1

가 , 5 ~ 35°C, 85 %

5.1.2

6.1.2.1

10%

6.1.2.2

가

6.1.2.3

10

5.2

5.2.1

5.2.2

5.3

5.3.1

“3.2.2 ”

$r^2 = 0.98$

5.3.2

“6.2

“ 3

5.3.3

3

(RSD %)

10 %

5.3.4.

1

5.3.4

(law data)

6.

6.1

6.1.1

2

50 mL

50 mL

10 mL

6.1.2

가

20 mL

1

6.2

()

5 mL 가

5 mL

25 ~ 30

1

, 640 nm

() 10 mL

7.

7.1 ()

3.2.2 (0 1)

(2)

- C : (ppm)

- A :

(uL)

- V : 가 (L)

- t : ()

- p : (mmHg)

7.2 ()

(3)

- C₁ : (ppm)

- Ca : (uL)

- Cb : (uL)

- 20 : (mL)

- V : (L)

- t : ()

- P : (mmHg)

7.3

ppm

(

KSA 3251 -1

.)

2. , ,

1.

1.1

- , 가 - (가 GC) .

1.

	(ppm)		(ppm)
	0.004	0.002	0.002 ~ 0.004
	0.06	0.02	0.02 ~ 0.06
	0.05	0.01	0.01 ~ 0.05
	0.03	0.009	0.009 ~ 0.03

1.2.

가

0.1 ~ 50 ppb(nmole/mole)

0.5 ppb

2.

2.1

(cold trap)

(thermal desorption)

가

2.2

(capillary column)

1 (R 1)

2.3

(Conditioning)

230 ±10

99.999 %

가
50 mL/

2 ~ 3

3.

3.1.

3.1.1
1

()
 () (Teflon), (Tedlar), (Polyester)
 가 가 가
 5 L
 L/ 가 가 가 1

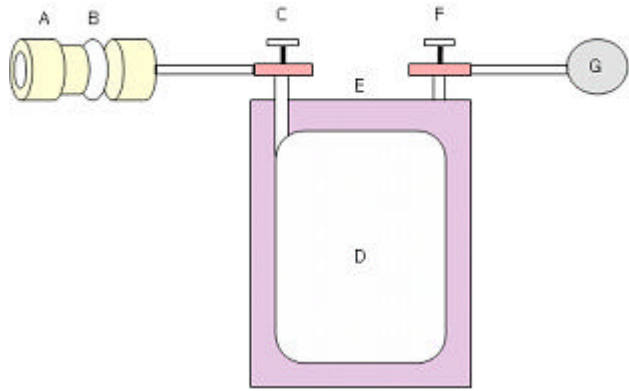

A: 시료채취용더 B: 필터
 C: 물소수지제 폭크 D: 시료채취 주머니
 E: 건조진공 용입상자 F: 흡입 폭크
 G: 유량계를 갖춘 용입 펌프

3.1.2
2

- GC
 가 (tubing)
 sulfinert 가 silico 2 ~ 4 mm
 -180 가 (: 가)
 DMCS (0.2 ~ 1 mm)
 150 °C 30 가 ()

120 °C GC (FPD), (PFPD), (AED),
 GC (SCD), (MS)

3.1.2.1 : (glass bead)

3.1.2.2 (30 L)

3.1.3 - GC

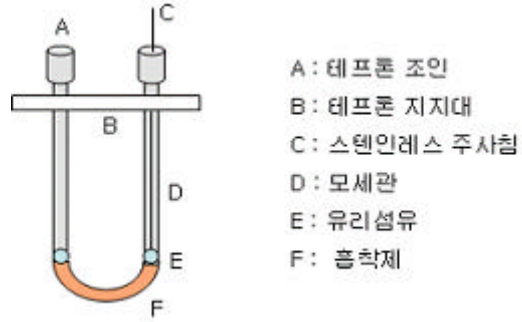

3

3 ~ 4 mm

10 N

) 0.8 ~ 1.0 g 가 2 (가
 -183 °C 200 °C 가
 가 -180 가

{ 가 }
 가

, 가 ,

가 (2 ~ 3 가)
 5 °C) 20 ~ 30 가
 GC 3.1.2

{ : 가 }

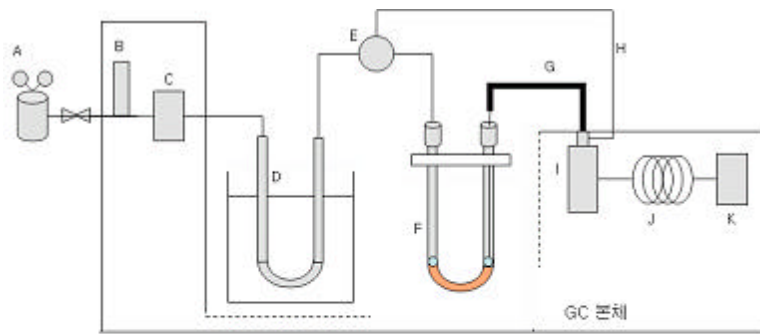

- A: 이동상가스
- B: 유량계
- C: 유량조절기
- D: 불순물 제거관
- E: 3방향 밸브
- F: 시료 주입관
- G: 시료 도입관
- H: 바이패스유로
- I: 시료 도입부
- J: 분리관
- K: 검출기

3.1.5 GC

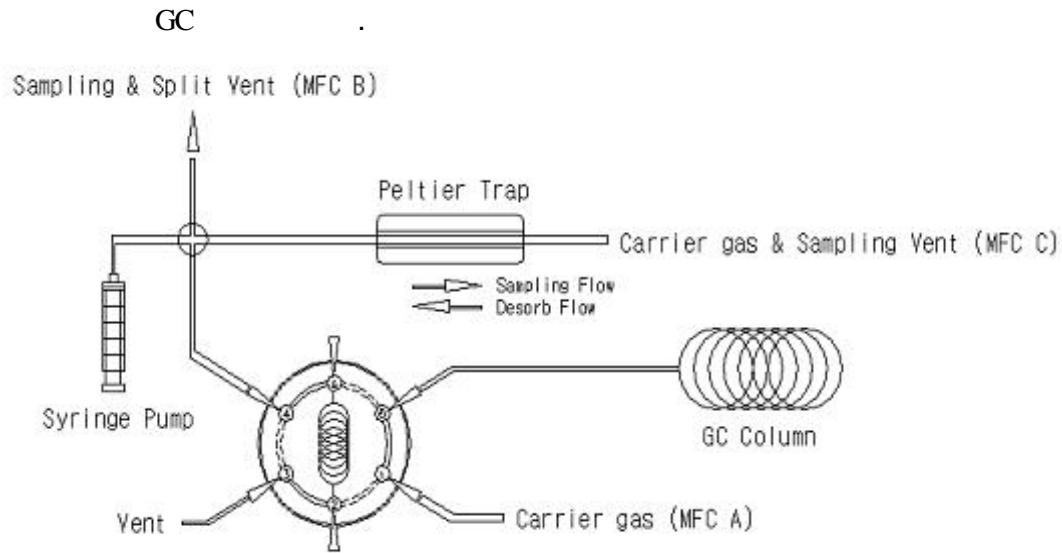

5. (U) - GC

1 ~ 600mL/가 (Digital
 Mass Flow Controller)가 1 L/가 (tubing)

silico (coating) sulfonert (tubing) 가
 가 (: nafion dryer)
 130 mm 2 ~ 3 mm, 6 ~ 6.6 mm(1/4")

[()]
 Carbopack C Silica-gel 2 Guard Carbopack
 C가 , Silica-gel 1 : 6

-30 가
 (syringe pump)
 5 mL (syringe) GC GC
 loop GC GC
 "3.1.2 "

3.2

- 3.2.1 가 (1 L) 10 L , ,
- 3.2.2 가 (1 mL, 5 mL)
- 3.2.3 (10 uL)
- 3.2.4 (5 L)
- 3.2.5 : GS-Q, DB-1
- 3.2.6 3 mm , 가 3 ~ 5 m 10 N
 가 60 ~ 80 mesh
 (dimethyldichlorosilane)

가) . -oxydipropyonitrile 25 % ((TCEP)

4,

4.1. 가

4.1.1 : 99% 가

- 4.1.2 : 99% 가
- 4.1.3 : 99%
- 4.1.4 : 99%
- 4.1.5 , , ,
가 (ppm)

4.2

- 4.2.1 :
- 4.2.2
- 4.2.3 ()
- 4.2.4 99.999 %

4.3 가

4.3.1 (Gas Tight Syringe)
ppm ppb . ppm 가
가 () . ppm (ppm 1
(purge) ppm . ppb , ppm
가 . ppm ppb . ppm ppb
가 가

4.3.2 가 ()
ppb

4.3.3 가
ppm , 10 L
가 . 10 N , . 99 %
가 가 1 mL 가 , 가
() , 1 .
99% 가 1 mL 가 , 3 uL
, 1 (micro-syringe) , 1
, 4 uL
1 , 10 .

ppm

ppb

{ }

가

1

(

100 ppm)가

100 ppm,

110 ppm 가

(1)

, - V(L) = 가 ,

) 25 °C, 1001 mbar ,

(2)

(3)

5.

5.1

(shelter)

5.2

가

가

가

, 5

1

가
가

가

1

5 L

(, ,

)

6. (QA/QC)

6.1

6.1.1

가 , 5 ~ 35 °C, 85 %

6.1.2

6.1.2.1

10%

6.1.2.2

가

6.1.2.3

10

6.2

6.2.1

6.2.1.1

가 가

가

6.2.1.2

6.2.2

6.2.3

6.3

6.3.1

6.3.1.1

6.3.1.2

6.3.1.3

6.3.2

6.3.2.1

6.3.2.2

6.3.2.3

6.3.2.4 GC

, split

6.3.2.5

6.3.2

6.3.2.1

6.3.2.2

6.3.2.3

6.4.5

6.5

6.5.1

(minimum detection limit, MDL)

0.5 ppb

7

3.14

6.5.2

(peak)

(RT: Retention Time)

?

3

10 ppb

10 %

5 ~ 20 ppb

$r^2 = 0.98$

6.5.3

(PFPD),

(AED),

(FPD),
(SCD),

(MS)

7.1.2

GC

(blank)

-183

100 mL

GC

(injecting)

가

80 ~ 90 °C

GC

3

(cold trap desorb)

가

150 °C

가

GC

7.1.3

가

(septum)

5 L

(가)

80% (

가)

가

100mL 50 mL/

2

(Dynamic Flow)

(Gas Tight

가

Syringe)

[가 : GC

zero air gas,

GC no peak]

7.1.4 가

가

가

()

가

-183

1 가

GC

		가
	,	- 180 , 80
GC		CP-SIL, 5CB (50 m x 0.53 mm x 5µm)

GC		5.0 mL/min
		-40 (4 min), 7 /min to 80 , 20 /min to 190
		200 mL (100 mL/min x 2 min)
FPD	가	100 mL/min, 75 mL/min
	()	250

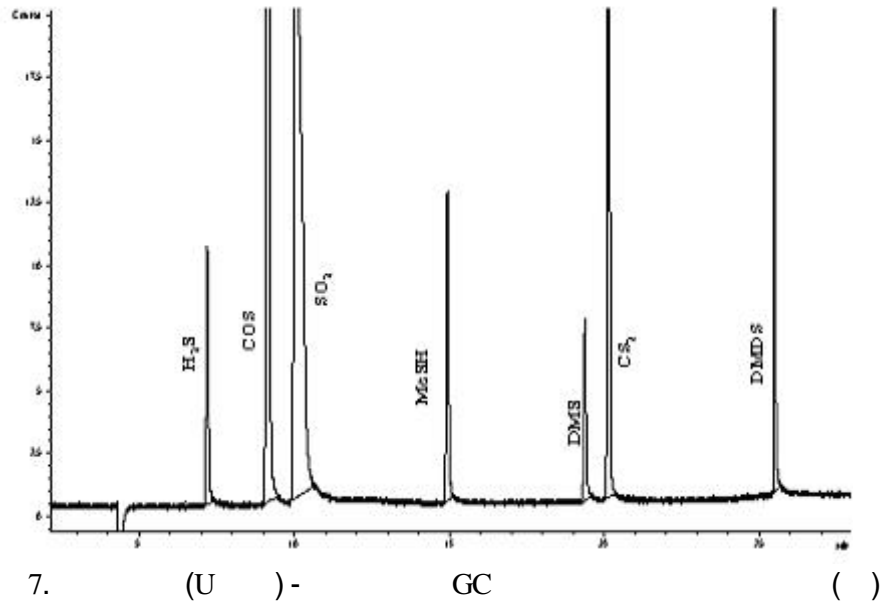

7.1.5
ppm 가 (Tee)
"7.1.3", "7.1.4 가"
" FPD PFPD
가
()
7.1.6
ppm 가
, , (0 ,
1 (uL)
(umole/mole, ppm)

$$C=A/V= A/(V' * 273/ [(273 + t)(p/1013)] \quad (4)$$

C : (ppm, 0 , 1)
 A : (uL)
 V' : 가 (L)
 V : 가 (L)(0 , 1)
 t : ()
 P : (kPa)

7.1.7

3. (: ppm)

	0.000	0.0000	KSA 3251 - 1
	0.00	0.000	
	0.00	0.000	
	0.000	0.0000	

7.2 - GC

7.2.1 : 7.1.1

7.2.2

GC

가 110 °C (blank) 가

가
 GC
 (cold trap desorb)
 °C
 가
 가
 100 mL
 가
 80 ~ 90 °C
 GC
 3
 150

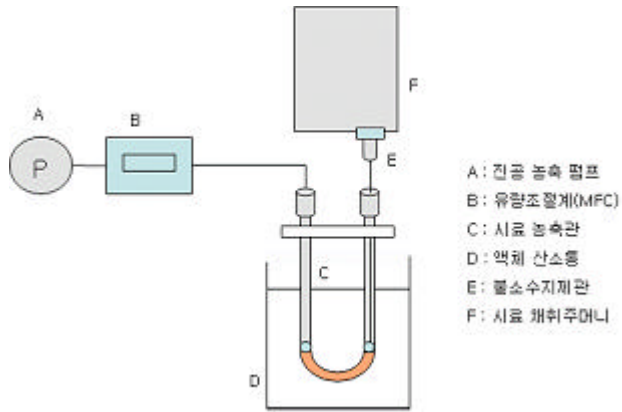

7.2.3

“7.1.3

7.2.4 가

가 ().
 가 , GC
 -183
 1 가

5. - ()

FPD, 200
3 mm x 2 m, glass
25% , ' -ODPN
130
80
, 30Mℓ/min

가

9. - GC

7.2.5 : "7.1.5 "
7.2.6 : " 7.1.6 "
7.2.6 : " 7.1.6 "

7.4 - - GC

7.4.1

(Syringe Pump)

(Syringe pump)

GC

7.4.2

GC

(blank)

-30

(
100 mL

(Syringe Pump)

가

가

()

(loop) GC

GC

GC

가

가

6. - - GC ()

GC		PFPD		(TD)	
Column	VP1, 50m x0.32mm x5μm	Detector temp.	250	Sampling(Adsorption) flow	50Mℓ/
Column flow	1.6 mL/	Flow rate (Mℓ/min)	Air=10.7	Sampling(Adsorption) temp.	- 30
Initial temp.	40		H ₂ =10.0	Desorption temp.	90
Final temp.	200	Carrier gas	He(13.8psi)	Desorption time	2min
Initial time	5min			Desorption flow	5Mℓ/
Final time	5min				
Ramp rate	15 /min				

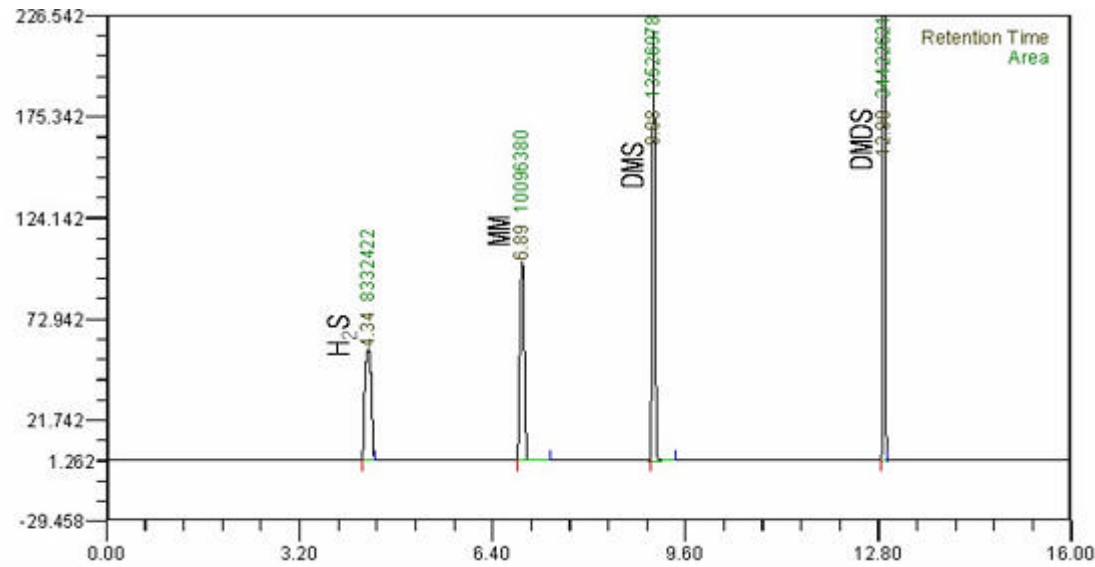

10. - - GC ()

- 7.4.3 : “7.1.3 ”
- 7.4.5 : “7.1.5 ”
- 7.4.6 : “ 7.1.6 ”
- 7.4.6 : “ 7.1.6 ”

3.

1.

1.1

가 - 가 (GC), - ,
가 .
0.005 ppm , 0.005 ~ 0.02 ppm 0.02 ppm ,

1.2

가 0.3 ~ 25 ppb .

2.

2.1 (thermal desorption)

가 .

2.2 (capillary column)

,
가 1 (R 1)
가 가

3.

3.1

3.1.1

가 1 ~ 5L/

20mL 5 %

2

3.1.2

가 47 mm,

0.3 um 2 ~ 10 L/ ,

2 ~ 10

5 %

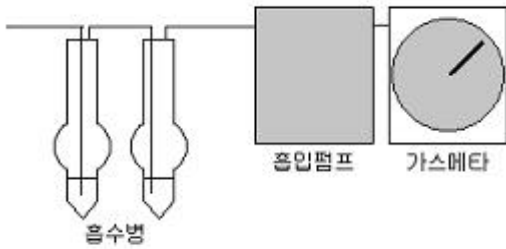

1.

3.2

GC

3.2.1

가

10 %

3 5 mm

가

가

{ }

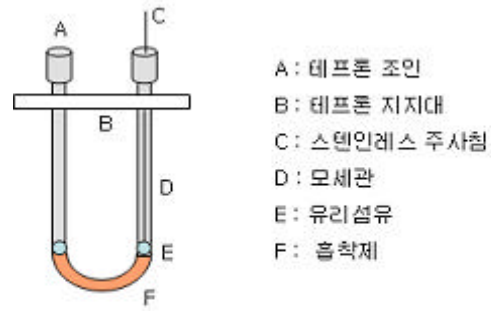

- A: 테프론 조인
- B: 테프론 지지대
- C: 스텐인레스 주사침
- D: 모세관
- E: 유리섬유
- F: 흡착제

그림 2 시료농축관

3.2.2 가
3

가

(FID : Flame Ionization Detector)

(NPD : Nitrogen Phosphorus Detector)

3 mm, 3 ~ 5 mm, 10 %
60 ~ 80 mesh
15 %, 15 %, 2 %

가

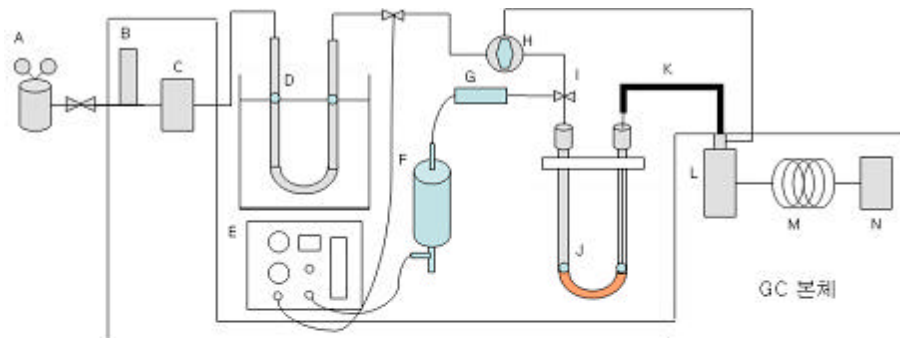

- A: 이동실가스
- B: 유압계
- C: 유량조절계
- D: 불순물 제거관
- E: 유량조절계
- F: 시료 분배법
- G: 탈수관
- H: 3방향 밸브
- I: 3방향 밸브
- J: 시료 농축관
- K: 시료 도입관
- L: 시료 도입부
- M: 분리관
- N: 검출기

그림 3 시료 분석 농축 장치

3.3

- GC

gas) GC (headspace
extraction) (fiber) GC (SPME : solid phase micro
4 .

3.3.1 :

3.3.2 : 345 rpm

3.3.3 (headspace vial)

(teflon) 가

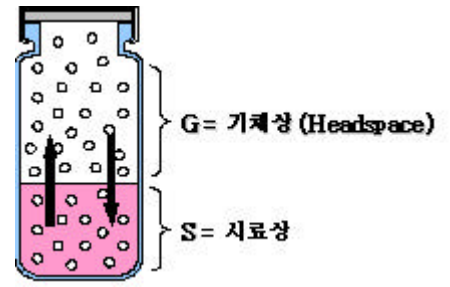

4. headspace vial

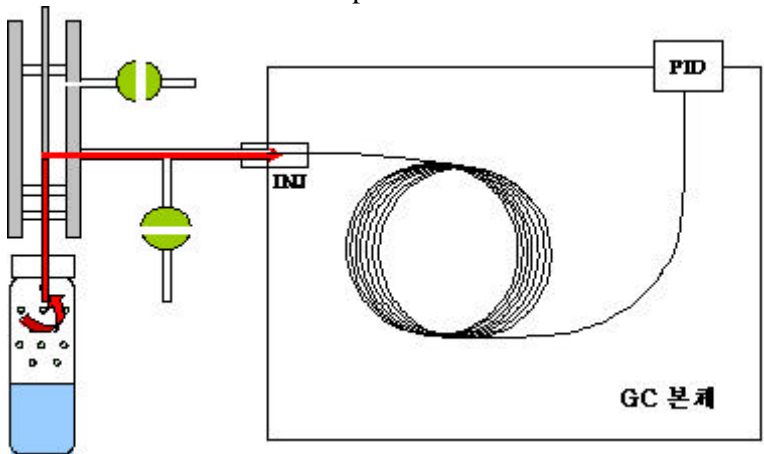

5.

3.3.4 (solid phase micro -extraction, SPME)
SPME 6 ,

siloxane (CAR/PDMS) 75 ~ 85 μm
 GC 250 °C 1 가 . SPME carboxen/polydimethyl-

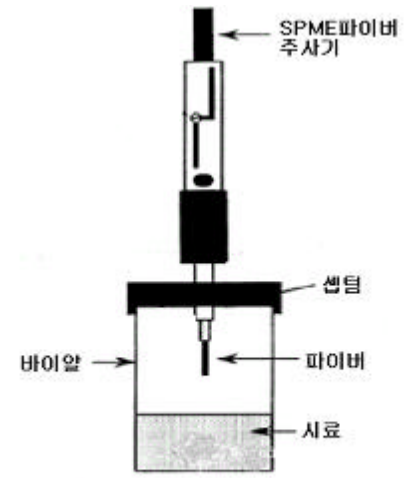

6. SPME

3.3.4 가

가 (FID : Flame Ionization Detector)
 (NPD : Nitrogen Phosphorus Detector)

4.

4.1 - GC

4.1.1

(KOH) 500 g 1 L

4.1.2

4.1.2.1

(20 ~ 40 %) 10 mL
 10 ~ 20 , 0.1 M

(%) (1)

- V_{Cl} : 0.1M HCl (mL)
 - N : 0.1M (mole/L)
 - f : 0.1M 가(factor)
 - V :
- (mL)
- M : (g/mole)
 - D :

4.1.2.1

1 M 1 M 2 1 (:1904 mg/L) 가
 (:1952 $\mu\text{g/L}$)
 2 3
 3

4.1.3

가

4.1.4 0.1 % (100 mg 100
 100 mL) 0.1 % (100mg
 mL) 5 : 1

4.1.6 359 mL , 1 mL

4.1.7 () 47 mm jj μm 1 가
 500
 1 N 1 mL

4.3.5 2 ,

(shelter) . ,
.

5.1

가 ,
20 mL 가
2
1 L/ 5
10 mL 2 .

5.2

(holder) 2 ~ 5 L/
가 5%
2 ~ 5 L/
2
2 ~ 5 L/ 50 L

6. (QA/QC)

6.1

6.1.1

가 , 5 ~ 35 °C, 85 %

6.1.2

6.1.2.1

10%

6.1.2.2

, 가

6.1.2.3 10

6.2

6.2.1

6.2.1.1 가 가 , 가

6.2.1.2

6.2.2

6.2.3

6.3

6.3.1

6.3.1.1

6.3.1.2

6.3.1.3

6.3.2

6.3.2.1 : , ,

6.3.2.2 :

6.3.2.3

6.3.2.4 GC , , , , ,

, split

6.3.2.5

6.3.2

6.3.2.1 :

6.3.2.2

6.3.2.3

6.4.5

6.5

6.5.1

(minimum detection limit, MDL)

7

3.14

0.5

ppb

6.5.2

3

(peak)

(RT: Retention Time)

?

3

5 ug/L

20 %

1 ~ 20 ug/L

r² = 0.98

6.5.3

1

6.5.4

(law data)

7..

7.1

-

GC

7.1.1

GC

(FID)

GC
(NPD)

7.1.2

7.1.2.1

10 ml

20

ml

7.1.2.3

가 5 50 mL 20 mL
"2.3
250 ~ 300 mL/ 가

70 가 -180 가
2 ~ 3 L

7.1.3 가

가 가 70
7.1.4 2 가 가
(,: 1 ~ 20 ug/L)

7.1.5

(1)

- C : (ppm)
- A : (ng)
- V : 가 (L)
- t : ()
- P : (mmHg)
- m : (ng)
- V₁ : (mL)

7.1.6

ppm

KSA 3251-1

7.2

- GC

7.2.1

Headspace
가
headspace

7.2.2

7.2.2.1

4 mL PTFE/Silicone
, 50 % KOH 5 mL KOH
20
GC

7.2.2.2

2 ~ 4 PTFE/silicone
, 50 % KOH 9 mL KOH
5 (shaker(345 rpm)
5)
GC

7.2.3 가

가

UA-Cabowax KOH treated (30 m × 0.53 mm × 1 μm)
(FID : Flame Ionization Detector)
(NPD : Nitrogen Phosphorus Detector)
200 가 GC
KOH 가 GC ..

1. - GC/FID ()

Gas chromatography condition			
Column	UA - Cabowax KOH treated (30 m × 0.53 mm × 1 μm)		
Carrier gas	He(5 mL/min)		
Injector Temp.	200		
Oven programing	40 (4min) 20 /min 120		
Detector			
FID	Temp.	230	
	Gas	H ₂	30 mL/min

Air 300 mL/min

Headspace Auto Sampler		
Temp.	needle	70
	transfer line	75
	oven	50
Timing	injection time	0.1 min
	pressurization	4.0 min
	withdrawal	0.1 min
	thermostatting	10 min
	GC cycle time	15 min

SPME (headspace) SPME 15
 fiber ? 가 SPME
 , 250 가 GC GC 3 GC

GC -NPD		5.0 mL/min
		140 °C (12 min)
		250 °C (split ratio 5:1)
	NPD	320 °C
	SPME	85µm Carboxen/PDMS
SPME		15 min
		3 min

7.2.4

(:1 µg/L ~ 20 µg/L)

7.3.1

7.2.5

(ug/L)

$C :$ ($\mu\text{mole/mole}$) (2)
 $m :$ (ng)
 $V_s :$ (L)
 $M :$ (g/mole)

$V_s :$ (L) (3)
 $Q :$ (L/min)
 $t :$ (min)
 $T :$ ()
 $P :$ (mmHg)

$m :$ (ng) (4)
 $C_x :$ ($\mu\text{g/L}$)
 $V_x :$ (mL)

7.2.6 : "7.1.6"

n -

iso -

1.

1.1

n -

iso -

2,4 -

(DNP H)

(High Performance Liquid

Chromatography,

HPLC)

(Gas chromatography,

GC)

	((ppm)		(ppm)
	0.1	0.05	0.05 ~ 0.1
	0.1	0.05	0.05 ~ 0.1
	0.1	0.029	0.029 ~ 0.1
n -	0.02	0.009	0.009 ~ 0.02
l -	0.006	0.003	0.003 ~ 0.006

1.2

1.2.1 DNP H

(HPLC/UV)

2,4-Dinitrophenylhydrazine(DNP H)가

DNP H

(acetonitrile)

(HPLC)

(UV)

360 nm

DNP H가

1
DNP H 가

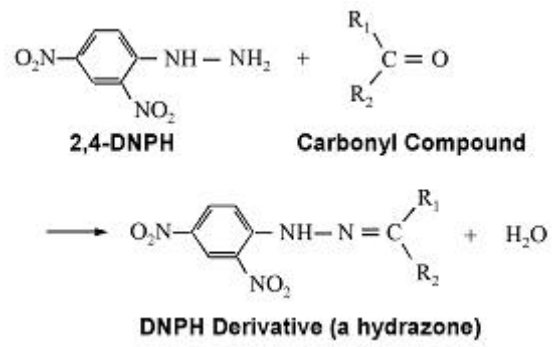

1.2.2 DNPH

DNPH

2,4-Dinitrophenylhydrazine(DNPH)가
(acetonitrile)
(gas chromatograph)

2.

(capillary column) :

1 (R 1)

3.

3.1

3.1.1 DNPH

DNPH- 가

DNPH

(breakthrough)가
DNPH

--	--

	75 µg	225 µg	640 µg	6400 µg
	150~250µm			
DNPB	1mg	3 mg	8.6 mg	86 mg
(Bed)	350mg		1 g	10 g
	0.1 µg			

3.1.2

1.5 g KI가 DNPB .
 ,

3.1.3

가 , 0.1 ~ 6 L/

3.1.4

5 % .

3.1.5 ?

3.1.6

, (1 mL), (1 mL), (5 mL),
 (10 mL), Luer type (10 mL), (10 mL).

3.1.7

3.2

3.2.1

HPLC (HPLC)
 2 , (2) ,

(ODS ()) 가
 (injector) (loop)

2 가
 20 ~ 100 uL

3.2.1.1

3.2.1.2

3.2.1.3

() :
 (1 L), (1 L, 4 L) :
 (25 uL, 250 uL), (25 uL, 250 uL) :

- 3.2.1.4 (100 uL) :
- 3.2.1.5 (4 L) :
- 3.2.1.6 (350 mL) :
- 3.2.1.7 :

3.2.2 (GC) :
 가 (FID : Flame Ionization Detector)

4.

4.1

DNPH ()
 n- iso- 2,4-

4.2

4.2.1 (acetonitrile : HPLC , HPLC)
 4.2.2 (HPLC , HPLC)
 4.2.3 (tetrahydrofuran : HPLC , HPLC)
 HPLC
 4.2.4 (ethylacetate)
 가 (1uL)
 2-4-

5.

5.1

5.1.1 가 (time weighted average)
 5.1.2 5
 5.1.3 1 ~ 2 L/min . DNPH
 가
 ? 3
 5.1.4 1.0
 cm(i.d.) × 4 cm KI 3
 DNPH

5.1.5

(:) (4) , 가 (10)

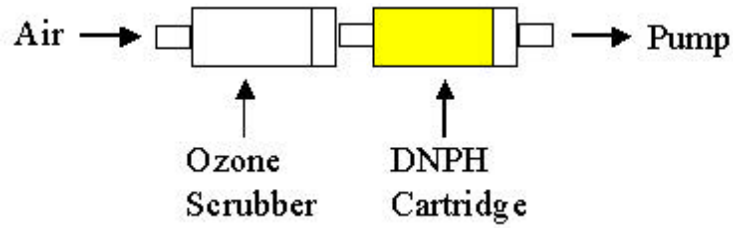

6. (QA/QC)

6.1

6.1.1

가 , 5 ~ 35 °C, 85 %

6.1.2

6.1.2.1

10%

6.1.2.2

가

6.1.2.3

10

6.2

6.2.1

6.2.1.1

가 가

가

6.2.1.2

6.2.2

6.2.3

6.3

6.3.1

6.3.1.1

6.3.1.2

6.3.1.3

6.3.2

6.3.2.1 :

6.3.2.2 :

6.3.2.3

6.3.2.4 GC/HPLC , split

6.3.2.5

6.3.2

6.3.2.1 :

6.3.2.2

6.3.2.3

6.4.5

6.4

6.4.1

(minimum detection limit, MDL)

i- ppb

6.4.2 (Field Blank) 가

6.4.3

(peak) (RT: Retention Time)

1 mg/L 10 % 1 ~ 10 mg/L r² = 0.98

6.4.4

1

6.4.5

(law data)

7.

7.1 DNPH (HPLC/UV)

7.1.1

7.1.1.1 60

7.1.1.2 10 mL (Luer type)

7.1.1.3 DNPH

7.1.1.4 (10 mL) 3 ~ 5 mL

7.1.1.5 1 DNPH

7.1.1.6 가 5 mL가

7.1.1.7 () DNPH

7.1.1.8 DNPH

7.1.1.9 가 2

7.1.2

7.1.2.1

0.1 ~ 10 mg/L

3 ~ 5

7.1.2.2

7.1.2.3 DNPH

	(g)	DNPH (g)	DNPH 1 mg/L (mg/L)
	44.1	224.2	0.196
	58.1	238.2	0.244
	72.1	252.4	0.286
	86.1	266.2	0.324

7.1.3 HPLC

7.1.3.1

DNPH

350 ~ 380

nm

가

360 nm

7.1.3.2

C₁₈

(4.6 mm × 150 mm)

(peak)

7.1.3.3

1 mL

(A)

(50:45:5, B)

7.1.3.4

B

7.1.3.5 HPLC

3

	20 uL (sample loop)
	ODS (C ₁₈) 4.6 mm × 250 mm (가)
	A : 100 (V %)
	B : / / 50/45/5 (V %)

	0-2 : B 100% 2-25 : A (0% 50% 가), B (100% 50%) 25-30 : A (100%)
	1.0 mL/min
	20 $\mu\ell$
	360 nm

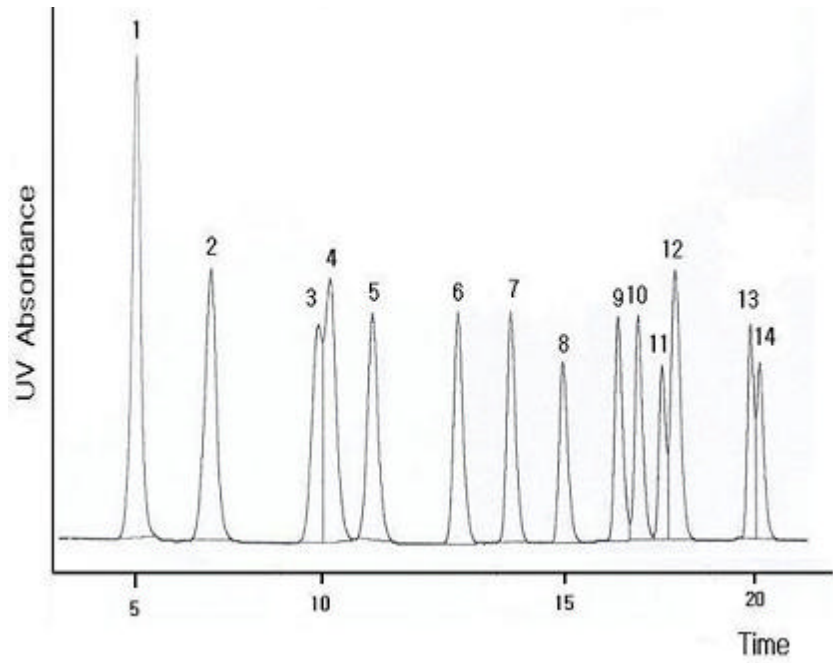

4.

HPLC ().

3.

1	Formaldehyde	CH_2O
2	Acetaldehyde	CH_3CHO

3	Acetone	CH_3COCH_3
4	Acrolein	$\text{CH}_2\text{CH}_2\text{CHO}$
5	Propionaldehyde	$\text{C}_2\text{H}_5\text{CHO}$
6	Crotonaldehyde	$\text{CH}_3\text{CHCHCHO}$
7	Butyraldehyde	$\text{CH}_3\text{CH}_2\text{CH}_2\text{CHO}$
8	Benzaldehyde	$\text{C}_6\text{H}_5\text{CHO}$
9	iso-Valeraldehyde	$(\text{CH}_3)_2\text{CHCH}_2\text{CHO}$
10	n-Valeraldehyde	$\text{CH}_3(\text{CH}_2)_3\text{CHO}$
11	o-Tolualdehyde	$\text{CH}_3\text{C}_6\text{H}_4\text{CHO}$
12	m-Tolualdehyde	$\text{CH}_3\text{C}_6\text{H}_4\text{CHO}$
	p-Tolualdehyde	$\text{CH}_3\text{C}_6\text{H}_4\text{CHO}$
13	Hexaldehyde	$\text{CH}_3(\text{CH}_2)_4\text{CHO}$
14	2,5-Dimethylbenzaldehyde	$(\text{CH}_3)_2\text{C}_6\text{H}_3\text{CHO}$

7.1.4

7.1.4.1 0.1 ~ 10 mg/L 3 ~ 5

7.1.4.2 x, y
(ug/mL) "7.1" DNPH

가

7.1.5

7.1.5.1 (1)

$$Q_A = \text{ (Ml/min)}$$

$$Q_1, Q_2, \dots, Q_N =$$

$$N =$$

7.1.5.2 (2)

$$V_m = \text{ (m}^3\text{)}$$

$$T_2 = \text{ ()}$$

$$T_1 = \text{ ()}$$

$$T_2 - T_1 = \text{ ()}$$

7.1.5.3

$$Q_A = \quad (\text{mL/ }) \quad (20 , 1) .$$

(3)

$$A_a = \quad (\text{ng})$$

$$A_b = \quad (\text{ng})$$

$$V_m = \quad (\text{L})$$

$$P_a = \quad (\text{mmHg})$$

$$T_a = \quad ()$$

7.1.5.4

(ppb) (20 , 1) .

(4)

7.1.6

	0.00	0.000	KSA 3251 - 1
	0.00	0.000	
	0.000	0.0000	
n -	0.000	0.0000	
l -	0.000	0.0000	

7.2 DNPH

(GC)

7.2.1

7.2.1.1

60

7.2.1.2 10 mL (Luer type)

()

7.2.1.3 DNPH

7.2.1.4 (10 mL)

3 ~ 5 mL

7.2.1.5

1 DNPH

7.2.1.6

7.2.1.7 (5 mL 가) DNPH

7.2.1.8 DNPH

7.2.1.9 가 2 ,

7.2.2

7.1.2

7.2.3 가

7.2.3.1 가 1 ~ 2 uL

7.2.3.2 (1) 1mL 가 가 .(가)

7.2.3.3 가 (FID)

7.2.3.4 (DB-5)

7.2.3.5 250

7.2.3.6 200 220

7.2.3.7 가 1.5 mL/

7.2.4

7.1.4

7.2.5

7.1.5

6.

1.

1.1

가
ppm,

0.4 ~ 0.8 ppm

0.8 ppm

0.4

1.2

1.2.1

- GC

(
가

, 2

1.2.2

(FID),

- GC

(MS)

(:)

가

(FID),

(MS)

2.

2.1

(thermal desorption)

2.2 2

(2nd thermal desorption)

가

2.3

(breakthrough volume)

5 %

2.4

(Safe sample volume, SSV)

2.5 (Retention volume)

2.6 (Conditioning)

) 99.999 % 350 (50 mL/min

2

2.7

가 1 (R 1) 가

3.

3.1

3.1.1

가

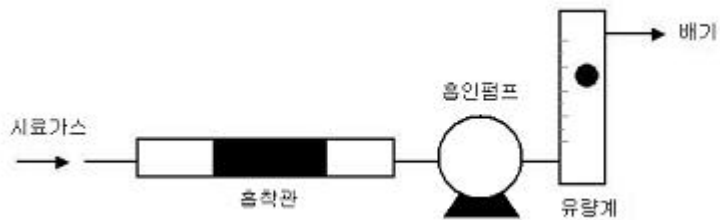

3.1.1.1

(breakthrough volume)

(conditioning)

PTFE (ferrules)

24

3.1.1.2

5 %

3.1.1.3

3.1.2

3.1.2.1

가

3.1.2.2

가

(cleaning)

6

가

가

(oil vapor)

가

(trap)

(back stream)

가

가

3.2

3.2.1

()

3.2.1.1

GC

3.2.1.2

가

3.2.1.3 99.999 % (cold trap)

가

(: -10)

3.2.1.4 (Splitting)

(Splitting)

3.2.1.5 10:1 (desorb)

가 가
-10 (thermal desorb) GC
가 (split)

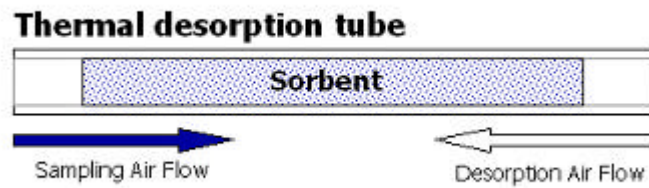

3.2.2 (column)

30 ~ 60 m

0.25 ~ 0.53 mm
3.2.3 (detector)

(Scan mode) (FID), (MS)
ppb

가 , 가
3.2.4 (carrier gas)

(99.999 %)

4.

4.1

Carbotrap 300

가)

(Tenax TA,

4.2

4.2.1

nmole/mole (ppb) 가 umole/mole (ppm) ppm 가 ppb (diluter)
가 ppb 가

4.2.2

99.9 %

(:) 5

0.1mg

(1000mg/L)

umole/mole (ppm)

nmole/mole (ppb)

4.3

5.

(shelter)

5.1

50 ~ 200 mL/

30

10 %

가

1

4

250 ~ 320

30 ~ 60

(thermal cleaning)

5.2

(0.05 mmHg)

(grap

sampling)

가

(6L)

(positive pressure)

(air pump)

2

2

가

6. (QA/QC)

6.1

6.1.1

가 , 5 ~ 35 °C, 85 %

6.1.2

6.1.2.1

10%

6.1.2.2

가

6.1.2.3

10

6.2

6.2.1

6.2.1.1

가

가

가

6.2.1.2

6.2.2

6.2.3

6.3

6.3.1

6.3.1.1

6.3.1.2

6.3.1.3

6.3.2

6.3.2.1

:

6.3.2.2

:

6.3.2.3

6.3.2.4 GC

, split

6.3.2.5

6.3.2

6.3.2.1

6.3.2.2

6.3.2.3

6.4.5

6.5

6.5.1

(minimum detection limit, MDL)

7

3.14

1 ppb(500 mL)

6.5.2

3

(peak) (RT: Retention Time)

?

3

10 %

10 ~ 100 ppb

100ppb

$r^2 = 0.98$

500 mL

6.5.3

6.5.3.1

- GC

“7.1.1

6.5.3.2

- GC

가

가

(,

6.5.5

1

5.3.4

(law data)

7.1 - GC

7.1.1

가

(가 (GC) (injector)) 가
 50 ~ 100 mL/min,
) 가 (가 가

7.1.2

7.1.2.1 가

7.1.2.2

7.1.2.3 200 ~ 350 , 30 ~ 100 mL/ 5 ~ 15

7.1.2.4 7.1.2.3 250 ~ 500 , 3 ~ 100 mL/ 1 ~ 15

2

7.1.2.5 2

Thermal desorption apparatus	
Parameter	Value
Tube desorption temp.	250
Tube desorption time	5 min
Cold trap temp.	-30
Desorption flow	25 ml/min
Trap High Temp.(2)	250
Trap Hold Time	2 min
Cold Trap Adsorbent	Tenax TA
Transfer Line Temp.	200
GC/MSD	
Column	SPB-1, - 624, VOCOL(60m, 0.32mm, 1 μm)
Column flow	1 ~ 2 ml/min

Oven temp.	40 (4 min)	10 /min	250
Ion source temp.	190		
Transfer line temp.	200		
Mass range	35 ~ 350 amu		
Ionization mode	EI (Electron ionization) mode		

7.1.2.6 가

GC GC
 GC/MS scan mode GC
 MS library
 EI(extracted ion)
 SIM(selected
 ion monitoring) mode

7.1.3

(: 1 ppm) (: 1 ~ 100 ppb)

(ng)

7.1.4

(ng)

C : ($\mu\text{mole/mole}$) (1)
 m : (ng)
 V_s : (L)
 M : (g/mole)

V_s : (L) (2)
 Q : (L/min)
 t : (min)
 T : ()
 P : (mmHg)

7.1.5

가 ppm

7.2

GC

7.2.1

-183

가

(Nafion dryer)

7.2.2

7.2.2.1

가

7.2.2.2

(mass flow controller)

100mL/

400 ~ 600 mL

70 ~ 80

가

(heating band)

7.2.2.3 가

GC

GC/FID

GC/MS

7.2.3

“7.1.3

”

7.2.4

“7.2.4

”

7.2.5

가

ppm

V.

1. /

1.

?

(Syringe Pump)

()

.

GC
Flame Photometric Detector)

GC/FPD, PFPD(Pulsed

2.

2.1 (Thermal desorption)

2.2 2 (2nd thermal desorption)

가

2.3 (Conditioning)

230 ± 10

99.999 %

가
50 Ml/min 2 ~ 3

2.4

가

가 1 (R 1)

3.

가 (GC/PFPD)

(TDU),

3.1 가 (GC/PFPD)

pg

PFPD

3.2 (TDU : Thermal Desorption Unit)

Thermal Desorption Unit

GC

1.

3.2.1

3.2.1.1 pump

(1 L/)

3.2.1.2 (Mass Flow Controller : MFC)

TDU

가

1~650min

1 ~ 300 mL/

3.2.1.3 (Flow & Pressure Controller)

MFC Power

Set Point Voltage (0 ~ 5

V DC)

MFC가

Control

3.2.1.4

Nafion Dryer

3.2.1.5

3.2.2

3.2.1.1

()가 , Pump

-30

가

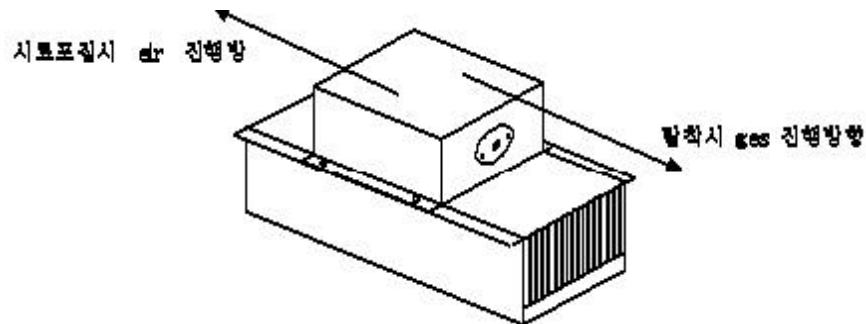

2.

flow

(flow)

3.2.1.2

130mm,

3 ~ 4 mm,

6 ~ 6.6 mm(1/4")

3.2.1

: 6-port valve(24V CE certified Electrical valve),
2,3 way solenoid valve(Low Internal Volume)

3.2.1 6-port valve GC carrier gas
MFC

3.2.2 2,3 way solenoid valve purge

3.2.3 carrier gas
purge 6-port valve

3.2.4 syringe pump 가 syringe GC GC
GC loop syringe GC GC

3.2.3

GC (loop) GC 5 mL

4. 가

4.1. 가

4.1.1 : 99% 가

4.1.2 : 99% 가

4.1.3 : 99%

4.1.4 : 99%

4.1.5 , , ,
가 (ppm)

4.2 가

4.3.1 (Gas Tight Syringe)

ppm 가 ppb , ppm 가
) . ppm (ppm 1

(purge)

ppm

ppb

가

가

ppb

ppm

ppb

4.3.2

ppb

가

()

4.3.3

ppm

가

, 10 L
10 N

가

99 %

가

1 mL

가

가

(99%)

가 1 mL

가

, 1

, 1

(micro-syringe)

3 uL

1

4 uL

, 10

ppm

ppb

[]

가

1 (100 ppm,

100 ppm)가
110 ppm

가

(1)

- V(L) = 가

)

25 °C, 1001 mbar

(2)

(3)

5.

5.1

5.1.1

5.1.2

50mL/

6.

“III.

6.

”

7.

7.1

7.1.1 On-line

7.1.1.1

(H₂S)

Nafion Tube

(Tube)

Cryogenic

95 %

Nafion Tube

, Tube

Air

N₂

가

2

(purge)

가

-30

1

가

가

(Tube) 가 ,

7.1.1.2

Glass Wool

7.2

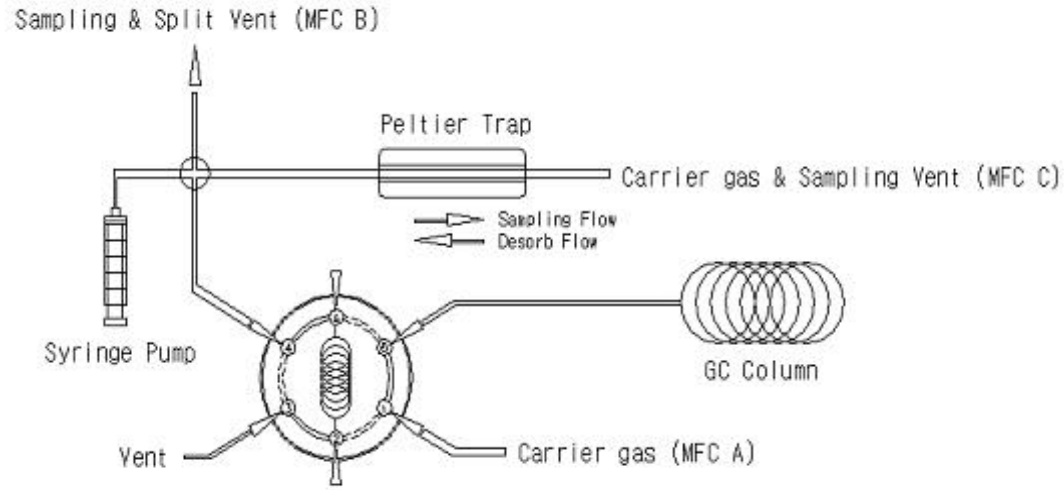

3.

7.2.1

7.2.1.1 (System Start)

가 , 가

MFC
(purge)

7.2.1.2 (Sampling)

2,3 way valve , cylinder,
MFC pump

가 sampling

7.2.1.3 (Purge vent)

2,3 way valve gas가 line
air carrier gas

7.2.1.4 (Syringe Pump)

6-port valve가 , 가 ,
flow 가
syringe 가

7.2.1.5 GC

GC GC 6-port valve loop GC

7.2.1.6

(System Cleaning)

6-port valve 2,3 way valve가 가 , 가

7.2.3

H₂S 15.2 pg, MM 11.3 pg, DMS 11.2 pg, DMDS 14.9 pg

1. ()

GC Conditions		PFPD Conditions		TD Conditions	
Column	VP1, 50m x 0.32mm x 5µm	Detector temp.	250	Sampling(Adsorption) flow	50Ml/min
Column flow	1.6Ml/min	Flow rate (Ml/min)	Air=10.7	Sampling(Adsorption) temp.	- 30
Initial temp.	40		H ₂ =10.0	Desorption temp.	90
Final temp.	200	Carrier gas	He(13.8psi)	Desorption time	2min
Initial time	5min			Desorption flow	5Ml/min
Final time	5min				
Ramp rate	15 /min				

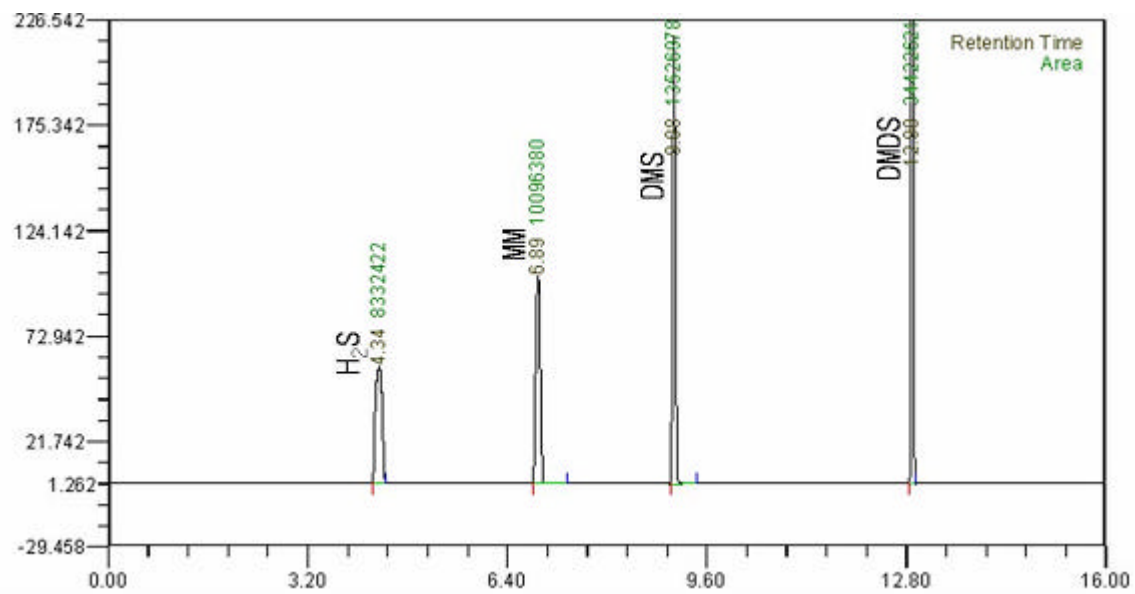

4.

2.

1.

(Differential Optical Absorption Spectroscopy : DOAS)

가 가 . 가

가 (I_t/I_0) , ,

Beer-Lambert .

$$I_t = I_0 \cdot 10^{-c} \quad (1)$$

- I_0 :

- I_t :

- ::

- L :

- C 가 ,

2.

(DOAS)

Beer-Lambert

3.

3.1.

, , , . , ,

3.1.1

/ (?)

3.1.1.1 (1) .
/ ?

180 ~ 2850nm

3.1.1.2

3.1.1.2

가

Czerny -Turner

Holographic

, 가 가 가

(Path)

PDA

(Library Data Base)

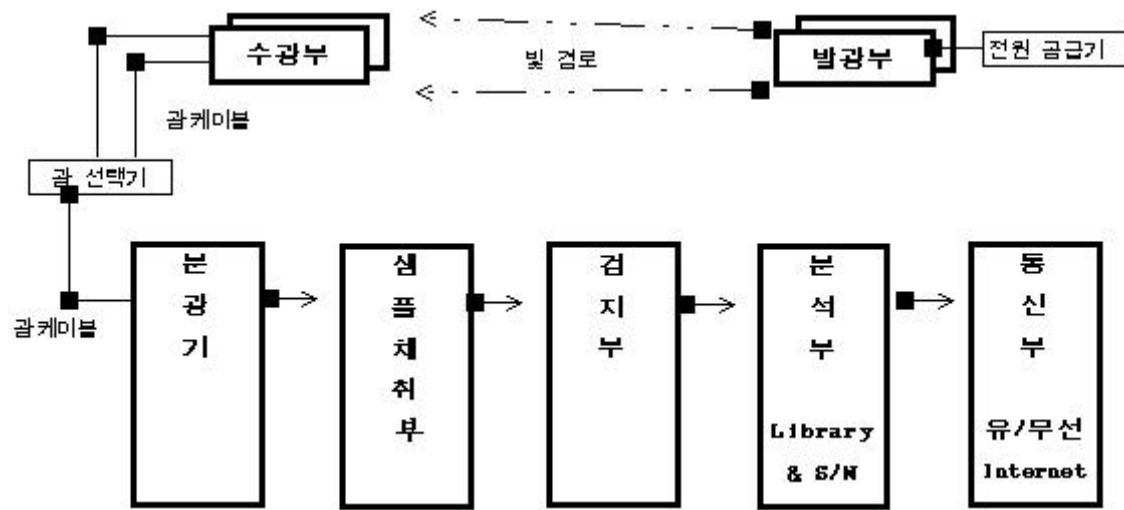

1.

3.2 ?

가

2

?

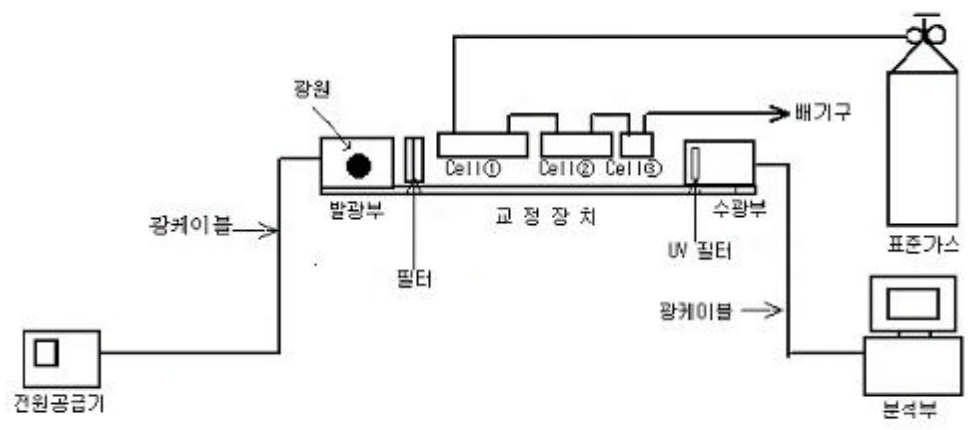

2.

3.3

3.3.1 : 0 ~ 2000 ppb

3.3.2

가

3

3.3.3

가

24

5%

3.3.4

2

가

가

(24)

3.3.5

4

가

가

3.3.6

가

A

가

가

+10%

-10%

10

10

B

C

B-A, C-A

(RANGE)

3.3.7

)

AC 1000V

1

가

(

3.3.8

)

KSC1031

KSC1302

(

DC500V

3.3.9

0 ~ 1V

1 ~ 5V(

500

)

4 ~ 20mA

가

3.3.10

가

가

가

가

90%

()

3.3.11

(NOx)

(20 ~ 30)

5

4.

4.1

4.1.1

4.1.2

4.1.3

4.1.4

4.1.5

4.2

4.2.1

4.2.2 가

4.2.3

4.2.4

4.2.5

? 가 2 ?

4.3.

가 가

4.4

4.4.1

(Path)

4.4.2

?

4.4.3

6

1

?

3.

1.

(Differential Optical Absorption Spectroscopy : DOAS)

가 가 .
(DOAS)

Beer-Lambert , 가

가 (I_t/I₀), , (가)

Beer-Lambert

$$I_t = I_0 \cdot 10^{-\epsilon \cdot C \cdot l} \quad (1)$$

- I₀
-, I_t
-,
-,
-, C 가 .

2.

(DOAS)

Beer-Lambert

3.

3.1.

3.1.1

/ (?)

3.1.1.1 (1 /) ?

, 180 ~ 2850 nm .

3.1.1.2

3.1.1.2

가

Czerny -Turner

Holographic

가 가 가

(Path)

PDA

(Library Data Base)

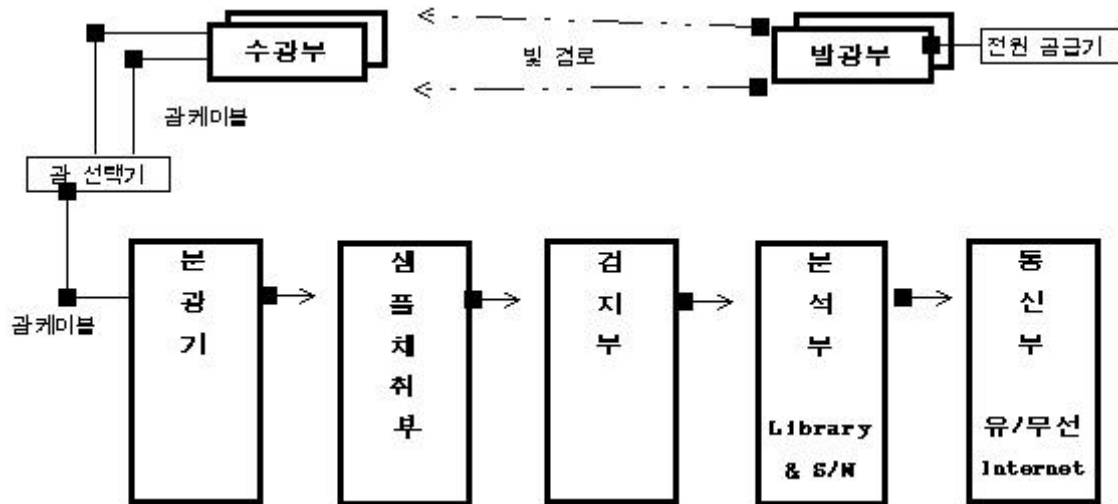

1.

3.2

?

가

2

?

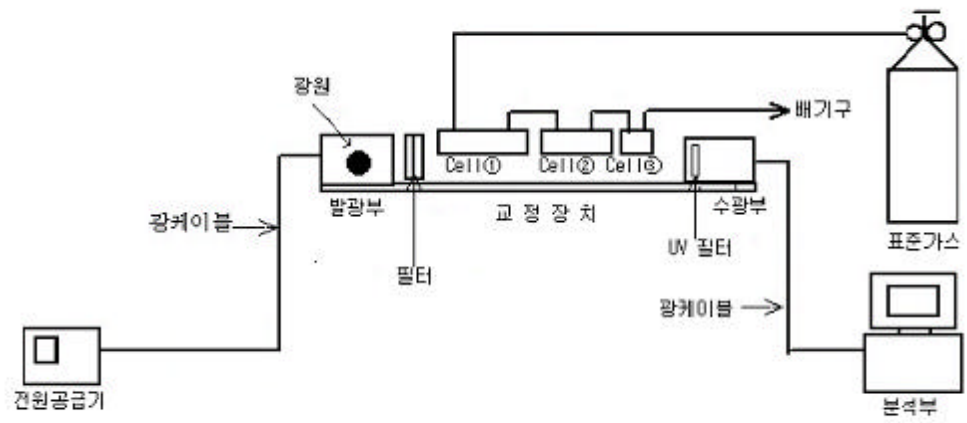

2.

3.3

3.3.1 : 0 ~ 2000 ppb

3.3.2

가

3

3.3.3

가

24

3.3.4 5%

3.3.4

2

가

가

(24)

3.3.5

4

가

3.3.6

가

가

가

가

A

+10%

10
10

B
C . B-A, C-A -10%
(RANGE)

3.3.7

)

AC 1000V 1 가

(

3.3.8

)

KSC1031 KSC1302

(

DC500V

3.3.9

가

0 ~ 1V 1 ~ 5V(

500)

4 ~ 20mA

3.3.10

가

가

가

가

90%

()

3.3.11

(NOx)

(20 ~ 30)

5

4.

4.1

4.1.1

4.1.2

4.1.3

4.1.4

4.1.5

4.2

4.2.1

4.2.2 가

4.2.3

4.2.4 가 ?

4.2.5 ?

4.3.

가 가

4.4

4.4.1 (Path)

4.4.2 ? 6 1

4.4.3 ?

4.

1.

(ammonia)

(amines)

amine), (trimethyl amine), (methyl amine), (dimethyl

2.

2.1

가

10 ~ 30

가

(

1).

(loop)

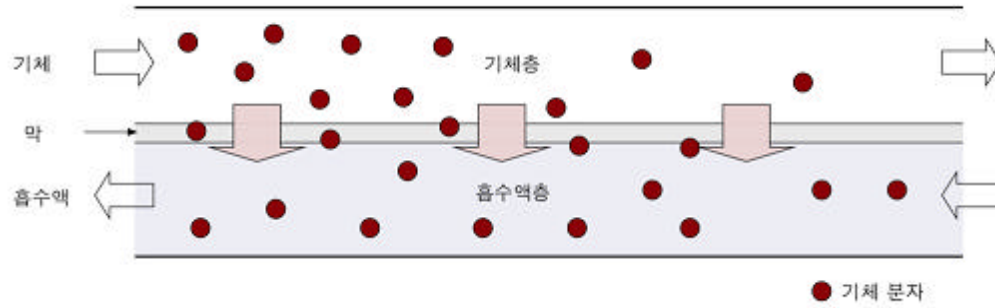

1.

2.2

()

2

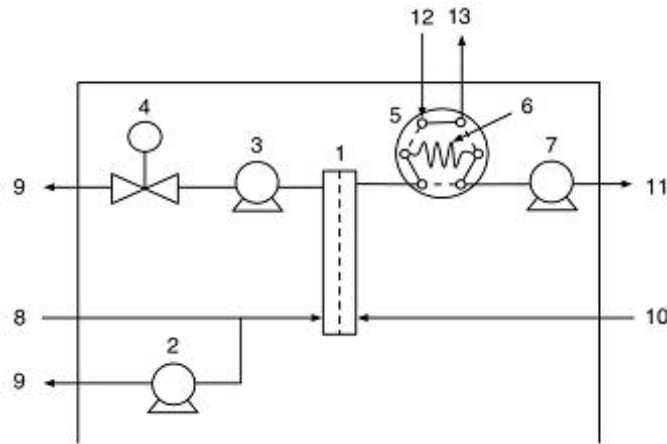

1: , 2: , 3: , 4: , 5:
 , 6: , 7: , 8: , 9: , 10:
 , 11: , 12: (eluent) (), 13:

2.

2.2.1

가 5 m

2.2.2

2.2.3

가

가

2.2.4

가

2.2.5

가

가

가

가

2.3

3

2.3.1

(suppressor)가

2.3.2

(2.2.4

)

2.3.3

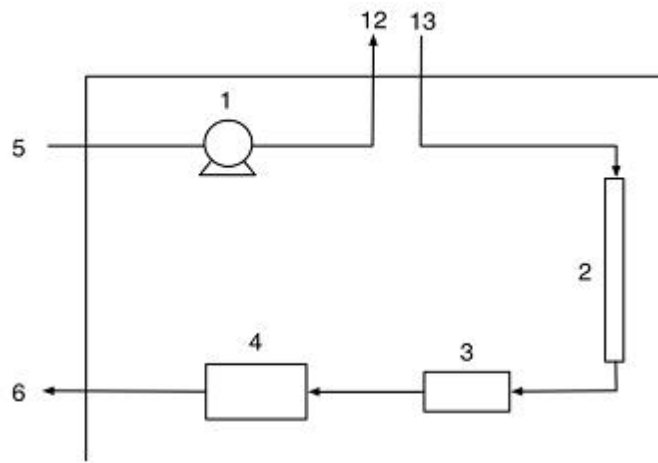

1: , 2: , 3: (suppressor), 4: , 5:
 6: , 12: (), 13:
 3.

3.

3.1

18 M

3.2

98% (ammonium nitrate, NH_4NO_3), (methylamine hydrochloride, $\text{CH}_5\text{N?HCl}$), (diethylamine hydrochloride, $\text{C}_2\text{H}_7\text{N?HCl}$),
 (trimethylamine hydrochloride, $\text{C}_3\text{H}_9\text{N?HCl}$) 1000 ppm

3.3

99% (methanesulfonic acid, $\text{CH}_3\text{SO}_3\text{H}$)

4.

4.1

4.1.1

100 ~ 200 μ L

가 가

가 가

4.1.2

10 L/

가 5 m

4.1.3

0.5 ~ 1.0 L/min

가 가

가 가 (6.1).
0.95

4.1.4

50 ~ 100 μ L/

가 가

가

1.

	150 μ L
	0.5 L/min
	70 uL/min

4.2

4.2.1

4.2.1

4.2.2

(background) (suppressor)가
가

4.2.3

500 ~ 1500 μ L
가

2.

	- SO ₃ H, 250mm x4mm
	40mM
	1.0 mL/min
	Self Regenerating Suppressor
	1000 μ L

5.

5.1

5.2

5.2.1

5.2.1.1

5.2.1.2

가

.

5.2.1.3

가

.

5.2.1.4

.

5.2.1.5

.

5.2.2

5.2.2.1

.

5.2.3.2

가

.

5.2.3.3

.

5,2,2,4

5,2,2,5

(2.2.4).

5.2.2.6

.

6. ()

6.1

가

.

6.1.1

가

()

가

6.1.2

(A, B)

6.1.3

가

가

가

(A)

(B)

6.1.4

6.1.5 가 가 가 B 가 A
 가 가 가 (I_A, I_B) 가 A
 가 (I_A, I_B)

6.1.6

A_B : (0.0 ~ 1.0)
 I_B : B (A B)
 가 (mV?min)
 I_B : B (B A)
 가 (mV?min)

6.1.7 가 가 10 ppbv 0.9

6.2

6.2.1 4가
 0 ~ 5 ppm, 0 ~

50 ppb 4 가
 6.2.2

6.2.3 2

6.2.4 R² = 0.98

6.3

C_A : A (ppbv)
 C_A : A () (ppb)
 E_A : A
 V_A : A (nL = 10^{-9} L)
 V_{air} : (L)
 t_{res} : , (min)
 m_A : A (nmol = 10^{-9} mol)
 V_{scr} : (mL)
 FW_A : A (g/mol)
 F_{air} : (L/min)
 F_{abs} : (mL/min)
 R : (0.0821 atm?L/mol?K)
 T : (K = + 273)
 P : (atm)

6.4

6.4.1

가 7 . 가

6.1 .

6.4.2

6.4.1

5 %

가 .
가 .

5.

1.

가
가

, 2

(FD)

.

2.

2.1 (capillary column)

1 (R 1)

2.2 (Conditioning)

230 ±10 99.999 % 가 50 mL/ 2 ~ 3

3.

Online Gas chromatograph 1
1

1. Online Gas chromatography system

3.1.

가 가

3.1.1

3.1.1.1

r

(semi-permeable

membrane)가
stainless-steel tube

Nafion Dryer

3.1.1.2

(Automated Thermal Desorption)

가

GC
(graphite, carbon molecular

sieve)

trap

가 ppm 가 ppb 가 .

3.2.1.2

가 가

Cleaning
, line

가 가 99.9999% 가

가 가 , ,
가 ,

MFC

MFC가 2

MFC

3.3

가

1

1.

			10 - 25		
			30 - 40%		
	Canister	Humid zero air Blank	2 ppbc (MDL) TNMOC 10 ppc		Humid zero air 가 purge

RT(Retention time) 가 ±0.5
 RT가 , 3가 (1, 5, 10ppb)
 (R²)가 0.995
 3.3.3 / 가

(RF) .
 (RPD)가 10% ,
 ±0.5 , % 80 ~ 120% .
 3.3.4 (Detection limit) (Limit of Detection)

noise .
 (Method Detection Limits, MDL) 99 % (US
 EPA) 가 "0" (Standard
 MDL 7 Deviation)

$$MDL = t_{(n-1, 0.99)} \times S.D$$

t : 1% student-t
 n-1 :
 S.D :

t(n-1) n-1, 1% student-t , n
 . MDL 0.25 ppb MDL
 0.25 ppb 가 MDL 1
 ppb 40 600 ml
 1/4 150 mL , 1ppb
 7 MDL 2ppbC
 3.3.5 (precision)

1 ppm 5ppb
 7 RSD
 2 RPD .

(relative standard deviation, RSD) 7
 (coefficient of variation, CV) , ±25%

$$RSD = S.D/AVE. \times 100 (\%)$$

RSD : relative standard deviation
 S.D : standard deviation
 AVE. : average

RPD(Relative percent difference) 2 ,
 ±20%

$$RPD = \frac{|S - D|}{(S + D)/2} \times 100 (\%)$$

RPD= relative percent difference
 S : First sample value
 D : Second sample value

3.3.6 (Accuracy)

1 ppm 7 5 ppb
 7 가 ± 20 %

$$(\% \text{ Bias}) = (\quad - \quad) / \quad \times 100$$

4.

4.1

<가 > 6.1 .

4.2

<가 > 6.2 .

5.

5.1

Desorbtion)

TD(Thermal
MFC
Nafion dryer

GC

5.2 가

가

(ppb)

5.3

(가)

2

2.

		Gas Chromatography	
Parameter	Value	Parameter	Value
Trap High	325	Column 1	PLOT (0.32 mm, 50 m, 5 m)
Trap Low	-30	Column 2	BP -1 (0.22 mm, 50 m, 1 m)
Ramp Rate	40 /sec	Carrier Flow	15 psi (5 Mℓ/min)
Trap Hold	1 min	Detector Temp.	250
Desob Time	1 min	Initial Temp.	44 for 12 min
Sampling Flow	15 Mℓ/min	1st Step	44 120 (7 /min), 0 min
Sampling Time	40 min	2nd Step	120 168 (5 /min), 6 min
Sampling Volume	600 Mℓ	3rd Step	168 200 (20 /min), 6 min

5.4

가
가

가

. 가 가
, 1ppm 가 가
1, 5, 10ppb canister 1, 5, 10 ppb 가
가 600 mL .

5.5

(ppb) .

6.

1.

(HPLC)

2,4-DNPH) 2,4- (2,4-dinitrophenylhydrazine, C₆H₆N₄O₄,
HPLC HPLC

(acrolein), (formaldehyde), (acetaldehyde),
(n-butyraldehyde), iso- (acetone), (propionadehyde),
n- (iso-butyraldehyde), n-
n-valeraldehyde), iso- (iso-valeraldehyde) 9

2.

2.1

가

10 ~ 30 (micron)

가

(1).

가

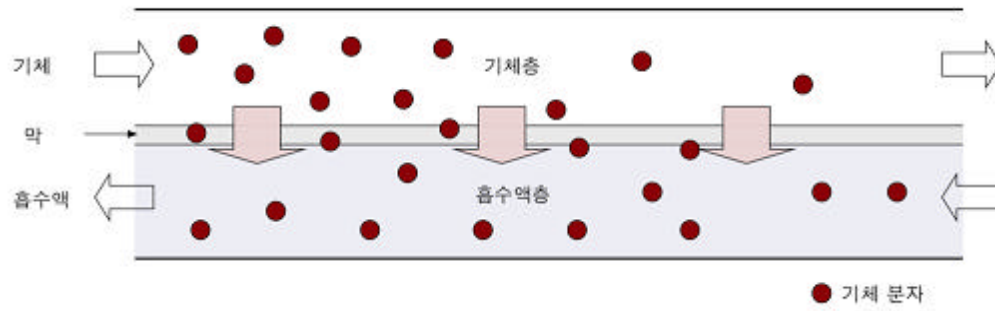

1.

2.2

()

2 .

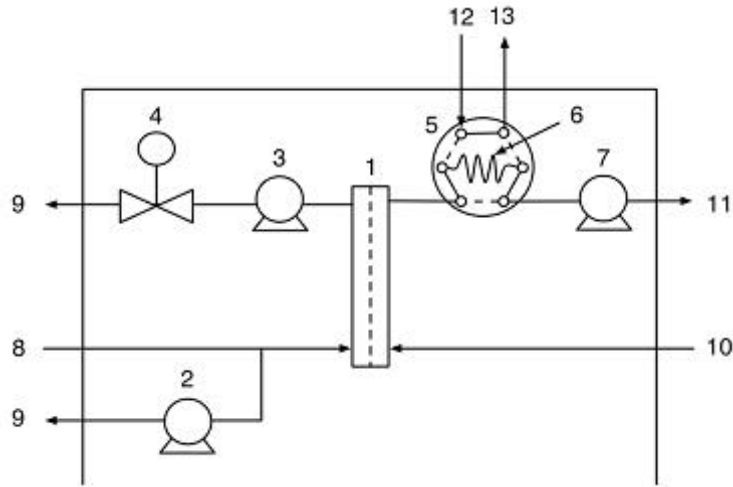

1: , 2: , 3: , 4: , 5:
 , 6: , 7: , 8: , 9: , 10: , 11:
 , 12: (), 13:

1.

2.2.1

가 5 m

2.2.2

2.2.3 가

가

2.2.4

가

2.2.5
가

가

가

가

2.3

2

2.3.1 9

-2,4-

..

2.3.2

2.3.3

4.

4.1

4.1.1

100 ~ 200 μ L

가 가

가 가

4.1.2

10 L/

가 5 m

4.1.3

0.5 ~ 1.0 L/min

가 가

가 가 (6.1)
0.95

4.1.4

50 ~ 100 μ L/

가 가

가

3.

	150 μ L
	0.5 L/
	50 μ L/

4.2

4.2.1

4.2.1

4.2.2 UV

360

4.2.3

20 ~ 60 μ L

가

가

4.

()

	C18, 250 mm \times 4.6 mm
	: = 60 : 40
	1.0 mL/
	40 μ L
UV	360 nm

5.

5.1

5.2

5.2.1

5.2.1.1

1 , 1

5.2.1.2

가

5.2.1.3

가

5.2.1.4

5.2.1.5

5.2.2

5.2.2.1

5.2.3.2

가

5.2.3.3

5,2,2,4

5,2,2,5

(2.2.4).

5.2.2.6

.6. ()

6.1

가

6.1.1

가 가 ()

6.1.2

가

(A, B)

6.1.3

가 가

가 (A) (B)

6.1.4

가 (I_A, I_B)

6.1.5

가 가 B 가 A

6.1.6

가 (I_A, I_B)

A_B : (0.0 ~ 1.0)

I_B : B (A B)

가 (mV?min)

I_B : B (B A)

가 (mV?min)

6.1.7

가 가 10 ppbv 0.9

6.2

6.2.1

4가

0 ~ 500 pptv 4 가

6.2.2

6.2.3

6.2.4

R² = 0.98

6.3

C_A : A (ppbv)
 C_A : A () (ppb)
 E_A : A
 V_A : A (nL = 10^{-9} L)
 V_{air} : (L)
 t_{res} : , (min)
 m_A : A (nmol = 10^{-9} mol)
 V_{scr} : (mL)
 FW_A : A (g/mol)
 F_{air} : (L/min)
 F_{abs} : (mL/min)
 R : (0.0821 atm·L/mol·K)
 T : (K = + 273)
 P : (atm)

6.4

6.4.1

가 7 가

6.1 .

500 pptv .

6.4.2

6.4.1

5 %

가 .

가

【 】

(QA/QC)()

(ambient air)

가

(SOPs),

가
가

가

1 (SOPs)

가

- (1)
- (2)
- (3)
- (4)
- (5)

(

.)

2 가
가.

blank 가

가

가

1)

(1) (bag)

가 (VOC-free gas)

GC

bag 가

(2)

가

GC

가 , 24

110kPa(830mmHg)

133Pa(1mmHg) 가

(3)

(bake)

GC

2)

가 , (가) , 가

(1) bag

(2)

(3)

3)

(1) bag

?

bag

가

, bag

가

(2)

(3)

가

가

가

4)

, ,

가

가

가

, bag

blank 가

가 .

,
가

1)

가 가

2)

가

,
가,
가,
가,

, peak가

4. 가

가.

1

가

±20%

(retention time)

(1 ±5%)

blank가

(blank) 가

. 5

(s) , 3 , 10

blank

= 3s (mg/m³N)

= 10s (mg/m³N)

5. blank

blank 가 ?

blank 가
1/10
blank

6. Travel blank

Travel blank

travel blank

travel blank

. Travel blank

10%

3

(e)

(s)

Travel blank

(e) (, 「travel blank 」

.) blank (a)

()

(a e)

travel

blank(a)

, travel blank (e)

blank(a)

Travel blank

(s)

(10s)

가

(f)

1/10(c)

(f<c)

travel blank (e)

Travel blank

(f)

1/10(c)

(f>c),

(d)

travel blank(e)

(f)

(d?f)

(d)

travel blank (e)

(a < e), travel blank

(f)

1/10(c)

(f > c),

가

(d)

travel

blank

(f)

(d < f)

,

가

가 가

가

, travel blank

2

가 30%

가

가

가

7. 가

가.

가

가 가 .

, travel blank

2 가

가

가 , 가 가

1

(1)

(2) bag,

, Canister,

(3)

(가 , 가 ,

가

)

(4)

(5)

8.

(1)

, ()
maker traceability

(2)

(3)

blank

travel blank

(4)

(5)

()

(6)